

# PCIe XMC 8-Lane Adapter



Eight (8) Lane PCI Express XMC to PCI Express Adapter with High Speed Communications Ports

## FEATURES

- Adapt one XMC PCI Express VITA 42.3 module to a desktop PCI Express slot
- Supports up to 8 lanes
- Transparent Operation
- 8 high speed expansion ports from XMC J16 using eSATA2 connectors
- 16 bits digital IO from J16 to MDR68
- IEEE 1384 XMC mechanicals
- >50W power provided to the module
- Robust end bracket
- Optional fan provides 12 CFM air flow
- Thermal plane and conductive rails improve module cooling
- ½ size PCI Express card

## APPLICATIONS

- Add XMC modules to standard PCIe host systems
- System expansion using high speed RIO links

## SOFTWARE

- No software required

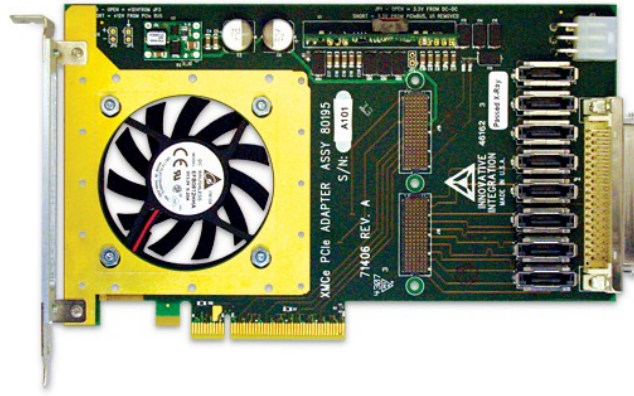

## DESCRIPTION

The PCI Express to XMC module adapter allows a single width XMC module to be used in a PCI Express slot. The XMC module is VITA 42.3 compatible and supports up to eight PCI Express lanes.

The P16 connector breakout provides convenient access to all P16 signals through an MDR68 connector and eSATA high speed connectors. eSATA connectors allow high speed connections to P16 SERDES-capable signals.

The adapter is completely transparent to PCI Express. All signals from the PCI Express host bus are connected directly to the XMC module.

More power to the XMC module may be provided by using the optional power connector to the adapter card. The power connector provides +12V to the adapter and powers an on-card 3.3V, 8A DC-DC module. The power connector is compatible with standard 0.165" pitch 12V PC power connectors.

Conduction cooling using VITA20 standard, as well as an optional fan, provide cooling to the XMC module.

The XMC module mounts securely to the adapter using standoffs and with the end bracket. The bracket mates to standard PMC end brackets and supports an EMI gasket. All connectors from the XMC end bracket are fully accessible.

Please be aware that an important notice concerning availability, standard warranty, and use in critical applications of Innovative Integration products and disclaimers thereto appears at the end of this data sheet. All trademarks are the property of their respective owners.



01/05/11

PRODUCTION DATA information is current as of publication date. Products conform to specifications per the terms of the Innovative Integration standard warranty. Production processing does not necessarily include testing of all parameters.

# PCIe XMC 8-Lane Adapter



This electronics assembly can be damaged by ESD. Innovative Integration recommends that all electronic assemblies and components circuits be handled with appropriate precautions. Failure to observe proper handling and installation procedures can cause damage.

ESD damage can range from subtle performance degradation to complete device failure. Precision integrated circuits may be more susceptible to damage because very small parametric changes could cause the device not to meet its published specifications.

## ORDERING INFORMATION

Product	Part Number	Description
PCIe-XMC Adapter	80173-0	PCIe-XMC 8 lane Adapter Assembly with on-board 3.3V, 8A supply (12V to 3.3V DC-DC)
PCIe-XMC Adapter	80173-0A	PCIe-XMC 8 lane Adapter Assembly without on-board 3.3V supply
Breakout and Cable	80116-1	Screw terminal assembly and 36 inch (0.91 m) pleated foil flat ribbon MDR68 cable
MDR68 cable	65057	MDR68 male to male cable assembly, pleated foil shielded flat ribbon, 36 inches (0.91 m)

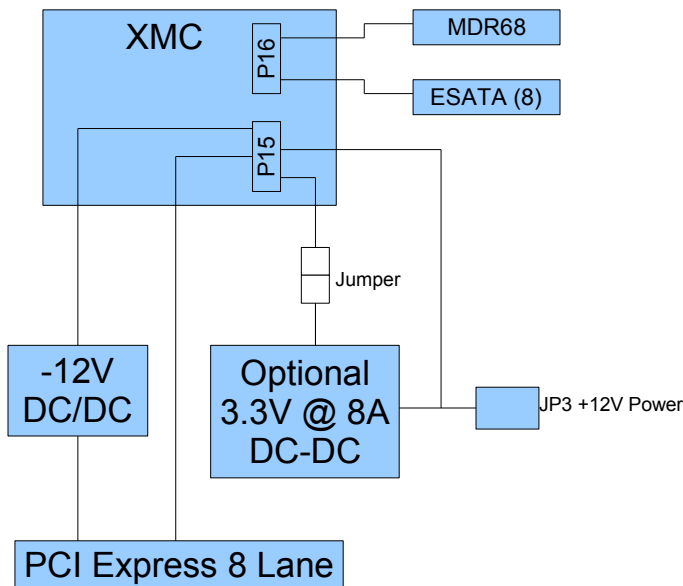

# PCIe XMC 8-Lane Adapter

## JP3 Auxiliary Power Connector

JP3 provides +12V to the XMC.

Pin	Power
1, 3, 5	+12V
2, 4, 6	Ground

**Caution:** incorrect connections may cause damage!

Mating connector is AMP 1586019-6 or equivalent.

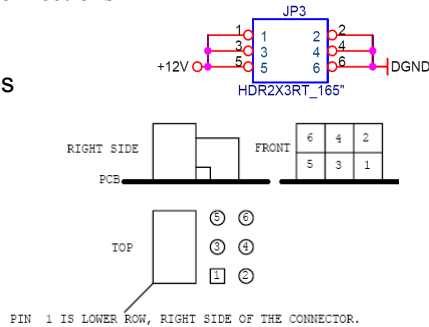

Physicals	
Form Factor	PCI Express half card
Size	4.20 in x 6.49 in
Weight	100g

Power Capability Delivered to the PMC	
Volts	Amps
3.3V	Supplied by PCIe bus for -0A option 8A max for -0 option
+12V	Supplied by the host computer
-12V	1A max (supplied by on-card DC-DC)

\*\* XMC cooling may be required

## JP4 - Breakout Connector for XMC P16

Signals are routed as 20 differential pairs (100 ohm), plus 8 single ended for 46signals total.

Signal pairs (P/N) are DIO0-1, 2-3..16-17, 20-21..36-37. All other signals (DIO 18, 19, etc) are routed single ended. Pairs are 50 ohm, 100 ohm differential characteristic impedance, suitable for LVDS or PECL.

Connector is 3M 10268-55H3VC or equivalent.

Mating connector is 3M 10168-6010EC or equivalent.

## JP4 Pin Assignments

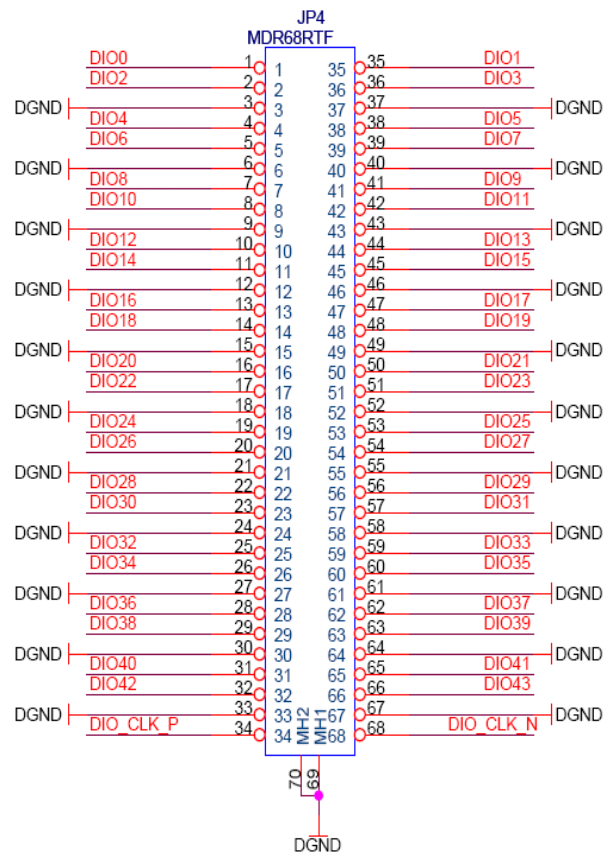

# PCIe XMC 8-Lane Adapter

## J16 Pin Assignments

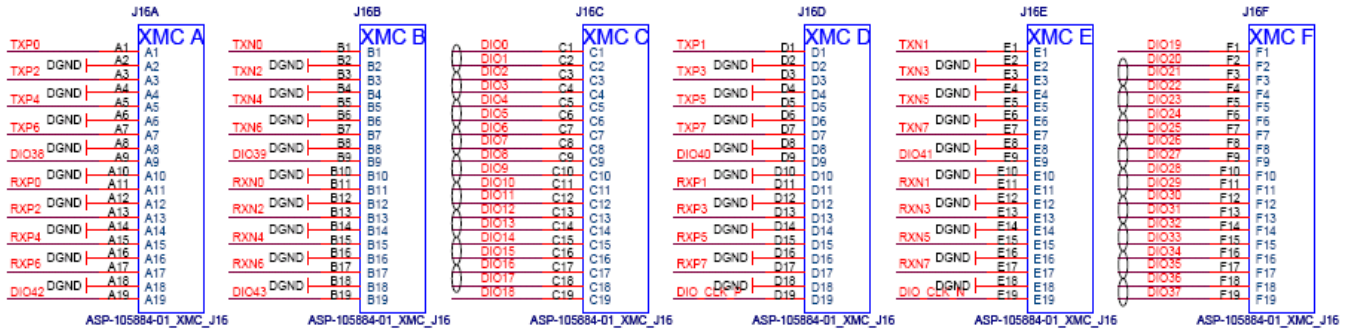

Signal	J16 Pins	JP4 Pins
DIO0/1	C1/C2	1/35
DIO2/3	C3/C4	2/36
DIO4/5	C5/C6	4/38
DIO6/7	C7/C8	5/39
DIO8/9	C9/C10	7/41
DIO10/11	C11/C12	8/42
DIO12/13	C13/C14	10/44
DIO14/15	C15/C16	11/45
DIO16/17	C17/C18	13/47
DIO18	C19	14
DIO19	F1	48
DIO20/21	F2/F3	16/50
DIO22/23	F4/F5	17/51
DIO24/25	F6/F7	19/53
DIO26/27	F8/F9	20/54
DIO28/29	F10/F11	22/56
DIO30/31	F12/F13	23/57
DIO32/33	F14/F15	25/59
DIO34/35	F16/F17	26/60
DIO36/37	F18/F19	28/62
DIO38	A9	29
DIO39	B9	63
DIO40	D9	31
DI041	E9	65
DI042	A19	32
DI043	B19	66
DIG_CLKP/N	D19/E19	34/68

# PCIe XMC 8-Lane Adapter

## Innovative Integration XMC Module Digital I/O Pinout Table

Note that the DIOxx signal names used in the diagrams and tables above are merely a convention and do not correlate to particular digital I/O signal names as they are defined on particular X5 XMC modules. For example, DIO0 in the above tables does not connect to DIO0 on an X5-400M module. The following table gives a convenient translation of the module-specific digital I/O signals to the MDR68 pin numbers.

X5-400M DIO	X5-210M, G12, GSPS, RX, TX DIO	JP4 Pins
0	0	35
1	1	16
2	2	36
3	3	17
4	4	38
5	5	19
6	6	39
7	7	20
8	8	41
9	9	22
10	10	42
11	11	23
12	12	44
13	13	25
14	14	45
15	15	26
16		48
17		50
18		51
19		53
20		54
21		56
22		57
23		59
24		1
25		2
26		4
27		5

# PCIe XMC 8-Lane Adapter

Innovative Integration XMC Module Digital I/O Pinout Table (cont'd)

X5-400M DIO	X5-210M, G12, GSPS, RX, TX DIO	JP4 Pins
28		7
29		8
30		10
31		11
32		13

# PCIe XMC 8-Lane Adapter

## High Speed Connectors

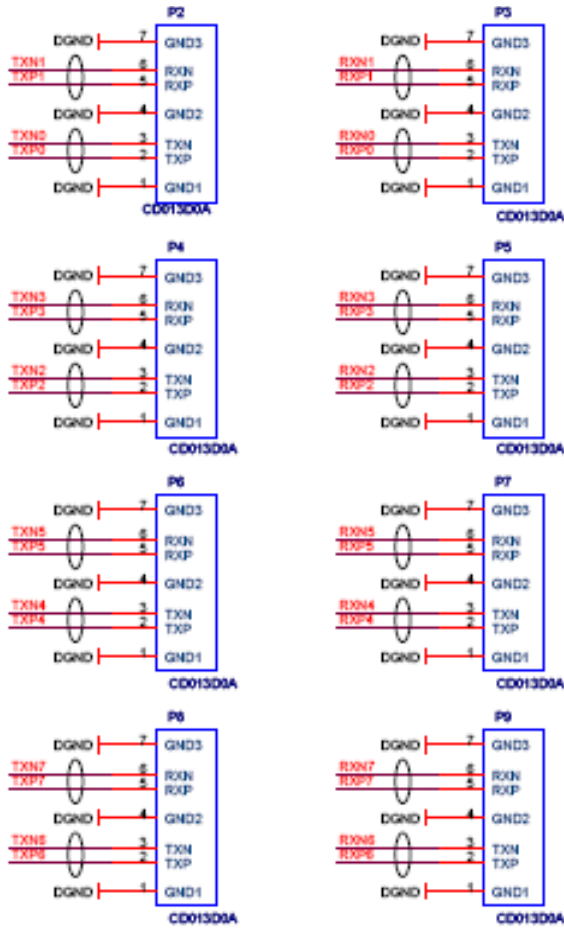

High Speed Serial Pair	J16 Pins (P/N)	ESATA Connector
TXP0/N0	A1/B1	P2
TXP1/N1	D1/E1	P2
TXP2/N2	A3/B3	P4
TXP3/N3	D3/E3	P4
TXP4/N4	A5/B5	P6
TXP5/N5	D5/E5	P6
TXP6/N6	A7/B7	P8
TXP7/N7	D7/E7	P8
RXP0/N0	A11/B11	P3
RXP1/N1	D11/E11	P3
RXP2/N2	A13/B13	P5
RXP3/N3	D13/E13	P5
RXP4/N4	A15/B15	P7
RXP5/N5	D15/E15	P7
RXP6/N6	A17/B17	P9
RXP7/N7	D17/E17	P9

# PCIe XMC 8-Lane Adapter

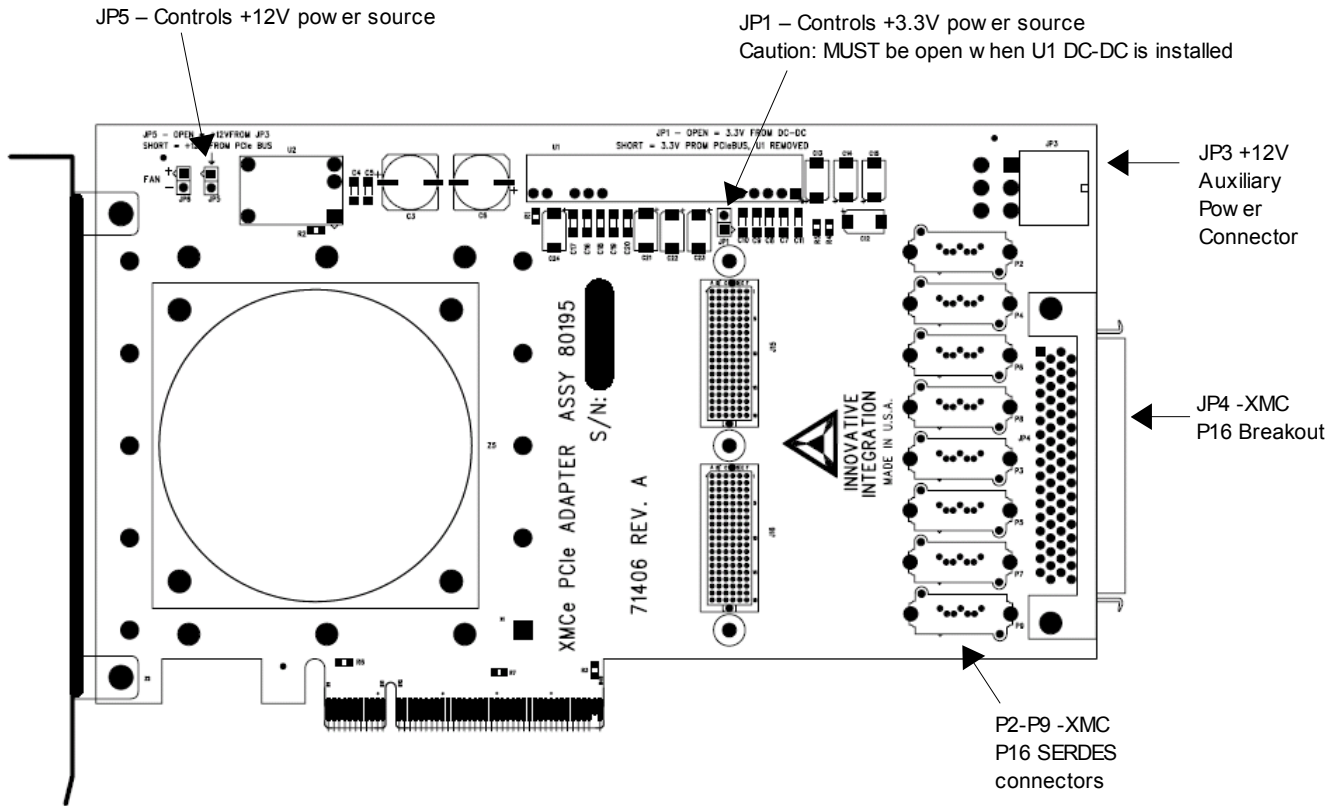

## Applications Information

### High Speed Serial Communications

The adapter card has 8 high speed serial lanes from the XMC card via J16 supporting Gigabit serial ports for intercard communications or expansion. The serial lanes connect directly to eSATA connectors. Standard eSATA cables can be used to connect multiple cards together to create high speed, dedicated communications channels between XMC modules. On Innovative's X5 module line, these are Rocket IO ports directly from the XMC Virtex5.

### Digital IO

Digital IO from J16 is directly mapped to the MDR68 connector on the adapter. There are 44 DIO bits that can be used for a variety of lower speed purposes such as triggering, controls and peripheral controls. Of the 44 bits, there are 19 signal pairs that can be used as LVDS or LVPECL. All DIO functionality is dependent on the XMC module itself; the adapter simply provides connections from J16 to the eSATA or MDR68 connectors.

### Power to the XMC Module

The XMC site provides +3.3V, +12V and -12V to the module. The adapter -0 version includes an on-board DC-DC power module providing 3.3V @ 8A to the XMC site, while the -0A version draws XMC 3.3V current only from the PCIe slot.

# PCIe XMC 8-Lane Adapter

## Jumper Setup

The jumpers and power connector work as follows:

JP1: controls whether the XMC 3.3V supply comes from the PCIe bus or from the onboard 3.3V DC/DC converter (U1). JP1 MUST be open if the DC/DC converter is populated, and MUST be closed if the DC/DC converter is not populated.

JP5: connects the board's +12V supply to the PCIe bus connector +12V supply pins. If JP5 is closed, the board may be installed in a host with JP3 disconnected, and +12V power will be drawn from the PCIe bus connector. If JP5 is open, the board MUST have a +12V connection to the system host power supply via JP3.

JP3: is intended as an alternate high-current path to support high power XMC modules (mainly X5 modules). This connector allows higher amounts of current than the PCIe edge connector, but requires an appropriately wired system power supply. This is a standard connector, and most PCIe equipped host systems should provide at least one mating connector on their power supply wiring harness.

Default configuration of the 80173-0 card is JP1 open, U1 populated, JP5 closed. Default configuration of the 80173-0A card is JP1 closed, U1 depopulated, JP5 closed.

## DO NOT HOT PLUG THE CONNECTOR!

Damage may occur.

## Cooling the XMC Module

Many XMC modules require special considerations to provide adequate cooling. Monitor XMC module device temperatures and add convective air flow if required to maintain within rated thermal limits.

The module provides conduction cooling using on-card heat sink and a dedicated thermal plane. The conduction cooling conforms to VITA20 specification for PMC/XMC module cooling. When a compatible module is used with the card, the thermal plane effectively conducts heat from the module to the carrier card and front bracket. System cooling is therefore more effective because of the heat spreading from the module to the carrier card.

An optional fan may also be installed for cooling. The fan provides approximately 12 CFM air flow. When the fan is installed, it blows air directly on the module and is very effective. The fan protrudes 10mm from the back of the card and does interfere with the adjacent slot in the PC.

## Module Mounting Hardware

The module can be securely mounted to the adapter for both conduction cooling and ruggedness. Two 10mm female threaded standoffs are used to secure the module to the adapter. If conduction cooling is used, cooling bars are secured to the card and the module using 2.5 mm screws. This hardware can be purchased from Innovative Integration.

## Software Driver

No software is required.



### Cables

Innovative offers a cable assembly (P/N 65057) and screw terminal/cable assembly (P/N 80116-1) for use in connecting to the MDR68 connector.

The cable assembly generally offers performance up to >50 MHz when differential signaling such as LVDS is used. Single ended signals are limited to about 10 MHz.

# PCIe XMC 8-Lane Adapter

eSATA cables are widely available as commodity items.

## **IMPORTANT NOTICES**

Innovative Integration Incorporated reserves the right to make corrections, modifications, enhancements, improvements, and other changes to its products and services at any time and to discontinue any product or service without notice. Customers should obtain the latest relevant information before placing orders and should verify that such information is current and complete. All products are sold subject to Innovative Integration's terms and conditions of sale supplied at the time of order acknowledgment.

Innovative Integration warrants performance of its hardware products to the specifications applicable at the time of sale in accordance with Innovative Integration's standard warranty. Testing and other quality control techniques are used to the extent Innovative Integration deems necessary to support this warranty. Except where mandated by government requirements, testing of all parameters of each product is not necessarily performed.

Innovative Integration assumes no liability for applications assistance or customer product design. Customers are responsible for their products and applications using Innovative Integration products. To minimize the risks associated with customer products and applications, customers should provide adequate design and operating safeguards.

Innovative Integration does not warrant or represent that any license, either express or implied, is granted under any Innovative Integration patent right, copyright, mask work right, or other Innovative Integration intellectual property right relating to any combination, machine, or process in which Innovative Integration products or services are used. Information published by Innovative Integration regarding third-party products or services does not constitute a license from Innovative Integration to use such products or services or a warranty or endorsement thereof. Use of such information may require a license from a third party under the patents or other intellectual property of the third party, or a license from Innovative Integration under the patents or other intellectual property of Innovative Integration.

Reproduction of information in Innovative Integration data sheets is permissible only if reproduction is without alteration and is accompanied by all associated warranties, conditions, limitations, and notices. Reproduction of this information with alteration is an unfair and deceptive business practice.

Innovative Integration is not responsible or liable for such altered documentation. Resale of Innovative Integration products or services with statements different from or beyond the parameters stated by Innovative Integration for that product or service voids all express and any implied warranties for the associated Innovative Integration product or service and is an unfair and deceptive business practice. Innovative Integration is not responsible or liable for any such statements.

For further information on Innovative Integration products and support see our web site:

[www.innovative-dsp.com](http://www.innovative-dsp.com)

Mailing Address: Innovative Integration, Inc.

2390A Ward Avenue, Simi Valley, California 93065

Copyright ©2007, Innovative Integration, Incorporated