

RTM-COMEX

V 1.0 9/2/11



Rear Terminal I/O Module for VPX-COMEX 3U OpenVPX CPU Card

FEATURES

- Rear Terminal IO card for VPX-COMEX CPU
 - 3U RTM module
 - OpenVPX VITA 46.10, VITA65
- Rear panel I/O
 - USB 2.0
 - 10/100/1000 Ethernet
 - DisplayPort
 - VPXI Timing Port
- Internal I/O (optional rear panel support)
 - 3x USB 2.0
 - Sample clock and trigger
- VPXI Timing Expansion Port
 - Extends VPXI timing signals to second chassis or custom equipment
 - Synchronize multiple chassis sampling
- Battery for CPU clock (removable)
- GPS interface
 - Serial port for GPS communication
 - PPS and 10 MHz inputs
 - Supports Trimble Mini-T GPS and others

APPLICATIONS

- VPXI-ePC signal processing applications
- Embedded Instrumentation and Control
- System timing expansion for VPXI-ePC

SOFTWARE

- Windows/Linux/VxWorks support
- C++ Host Tools



DESCRIPTION

The RTM-COMEX is a 3U OpenVPX RTM Module for the VPX-COMEX CPU card. The RTM-COMEX provides I/O support for the VPX-COMEX including USB, Ethernet, DisplayPort and VPXI Timing Expansion.

Standard I/O features include four USB 2.0 ports, Gb Ethernet, and DisplayPort audio-video. The RTM_COMEX integrates 4 port USB hub supporting USB2.0 , with one rear panel port and three internal ports. A socketed for 25mm coin batteries connects to VPX P0 for system battery.

The RTM-COMEX has a timing expansion port for VPXI timing signals. The rear panel port provides clock and trigger to other VPXI systems or user equipment.. Timing clocks and signals are routed to the VPXI system timing controls so that multiple systems can run in synchronization and perform coordinated sampling. User-defined signals may be used for further customization.

The RTM-COMEX also has an interface to a GPS for communications, PPS and timing reference. A GPS unit can be integrated with the VPX-COMEX as a timing reference using the 10MHz and PPS signals from the GPS for clock reference and triggering. A UART interface in the VPX-COMEX, with supporting software, can use a Trimble Mini-T or Thunderbolt GPS.

The card requires a a double-wide (8HP) slot. REDI covers are available.

Software tools for host development include C++ libraries and drivers for VxWorks, Windows and Linux. Application examples demonstrating features are provided for the VPX-COMEX.

Please be aware that an important notice concerning availability, standard warranty, and use in critical applications of Innovative Integration products and disclaimers thereto appears at the end of this data sheet. All trademarks are the property of their respective owners.



09/04/11

PRODUCTION DATA information is current as of publication date. Products conform to specifications per the terms of the Innovative Integration standard warranty. Production processing does not necessarily include testing of all parameters.

RTM-COMEX



This electronics assembly can be damaged by ESD. Innovative Integration recommends that all electronic assemblies and components circuits be handled with appropriate precautions. Failure to observe proper handling and installation procedures can cause damage. ESD damage can range from subtle performance degradation to complete device failure. Precision integrated circuits may be more susceptible to damage because very small parametric changes could cause the device not to meet its published specifications.

ORDERING INFORMATION

Product	Part Number	Description
RTM-COMEX	80276	3U OpenVPX Rear Terminal Module for VPX-COMEX; 4 USB 2.0 ports (3 internal and one rear panel), Ethernet RJ-45, rear panel clock and trigger expansion port, GPS support, battery, DisplayPort connector.
Software	57001	Malibu software installation DVD including drivers for Windows and Linux.

RTM-COMEX

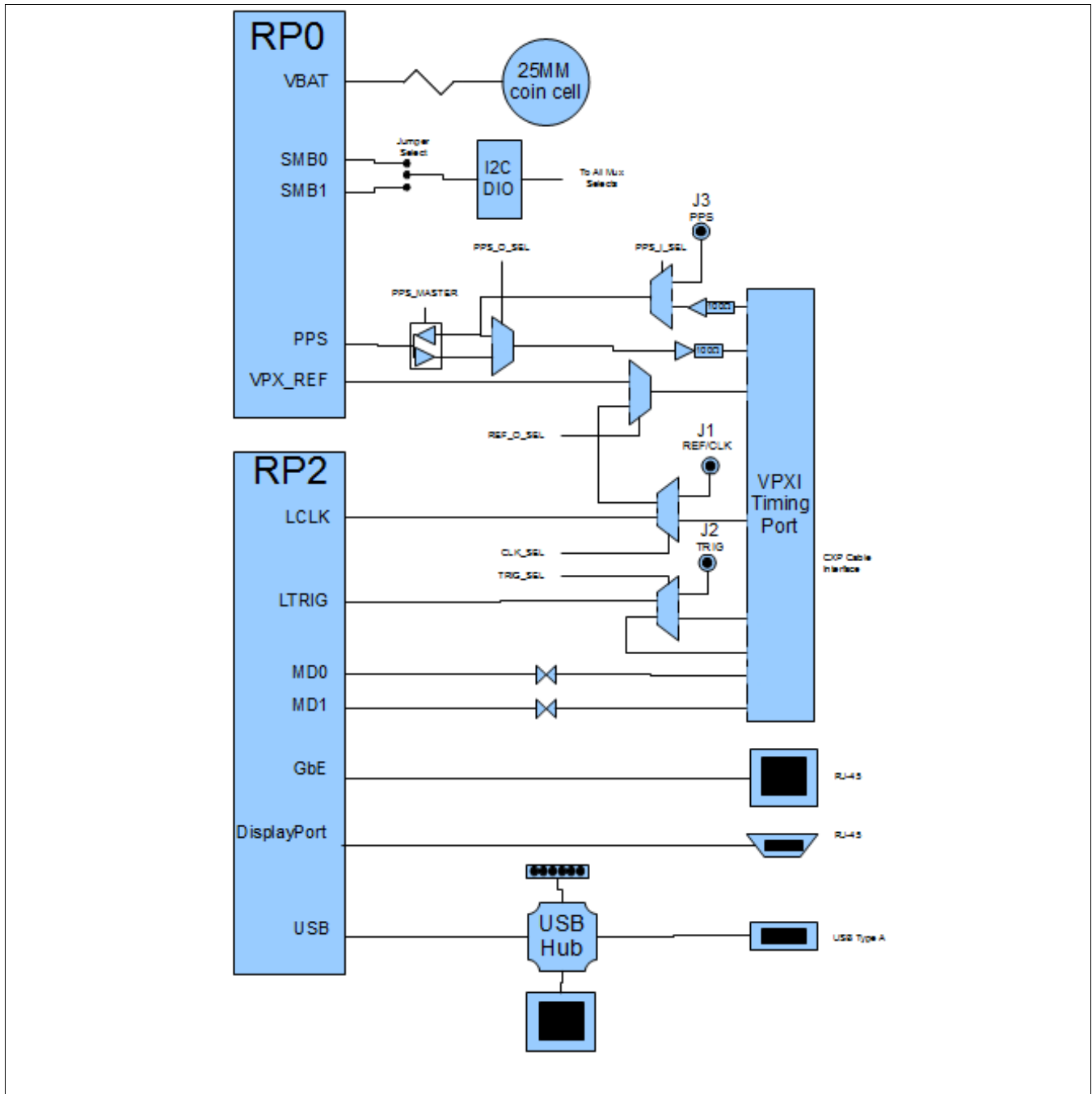

RTM-COMEX

Standard Features

VPX	
Size	3U, 81.75 x 100 mm 8HP width (44mm)
Cooling	Forced-air
Standards	ANSI/VITA 65 OpenVPX compatible ANSI/VITA 46.10 RTM for VPX ANSI/VITA 48.1 Air Cooled VPX
OpenVPX Connectors	RJ0: system connectors RJ2: IO

IO	
USB	4 x USB 2.0 ports (host) 1x rear panel Type A 2x internal ports using RJ-45 1x 10 pin header 500mA rate power
Hub	Cypress CY7C65640A-LTXC
Ethernet	RJ-45 for 10/100/1000 Ethernet
Video	DisplayPort

Timing Inputs	
PPS	SMA; LVCMOS, $V_{il} < 0.7V$, $V_{ih} > 2.2V$, 3.6 V max
Clock	Input to VPXI LCLK SMA, 50 ohms, AC coupled, 20VDC max $V_{min} = 400mV_{p-p}$, $V_{max} = 1.6V_{p-p}$ $F_{max} = 800$ MHz
Trigger	Input to VPXI LTRIG SMA, 50 ohms, AC coupled, 20VDC max $V_{min} = 400mV_{p-p}$, $V_{max} = 1.6V_{p-p}$ $F_{max} = 800$ MHz

VPXI Timing Expansion Port	
Ports	1, rear panel
Connector	Molex 76105-0584
Mating Cable	Molex 111025-1201 (1 meter) Molex 111025-1205 (5 meter)
Triggers	Input: 1x LVDS; 1 GHz max rate 1x LVDS; 100 MHz max rate Output: 1x LVDS; 1 GHz max rate 1x LVDS; 100 MHz max rate
Clocks	Input: LVDS; 1 GHz max rate Output: LVDS; 1 GHz max rate
Timing Reference	Input: LVDS pair; 100 MHz max Output: LVDS pair; 100 MHz max
User IO	2x differential pairs

GPS Port	
UART Connector	MOLEX 70553-0005
Antenna Power	500mA max
Inputs	PPS: SMA 10 MHz: SMA
Supported GPS Receivers	Trimble Mini-T Trimble Thunderbolt

Power	
Input	3.3V @ 0.7A
Battery	25mm coin cell socket polarity protection 0.4 mA max VPX J0 battery
Hazardous Materials	Lead-free and RoHS compliant

RTM-COMEX

Architecture and Features

The RTM-COMEX provides standard PC connections for the VPX-COMEX DisplayPort, Ethernet and USB. Timing features for clock sharing and GPS integration are also provided.

The RTM-COMEX connects to RJ0 and RJ2 of the VPX bus according to VITA 65 OpenVPX standard.

USB Ports

The VPX-COMEX has one USB port through RJ2 that connects to a 4-port hub on the RTM-COMEX. The hub expands the USB to 4 ports, one on the rear panel and three for internal cabling.

The hub is Cypress CY7C65640A device, which is a performance USB hub capable of full rate USB 2.0 data transfers. Each downstream USB port has up to 500mA power supply. The hub supports hot-plug for the USB ports and monitors each for over-current conditions.

Triggering and Sample Clocks

System timing features on the RTM-COMEX provides a VPXI timing expansion port for the VPXI-ePC. This allows the VPX-COMEX timing circuitry to receive a clock, trigger and PPS from other another VPXI-ePC or other devices.

Timing Signal	Source	Destination	Signal Type
Trigger Input	VPXI Timing Port	VPX-COMEX	LVDS
	J2	VPX-COMEX	50 ohm, AC-coupled, Vmin =400mVp-p, Vmax = 1600mVp-p
Trigger Output	VPX-COMEX FPGA	VPXI Timing Port	LVDS
Clock Input	VPXI Timing Port	VPX-COMEX	LVDS
	J1	VPX-COMEX	50 ohm, AC-coupled, Vmin =400mVp-p, Vmax = 1600mVp-p
Clock Output	VPX backplane refclk or J1	VPXI Timing Port	LVDS
PPS	VPX backplane, J3, or VPXI Timing Port	VPX backplane, VPXI Timing Port	Multi-drop LVDS
Multi-drop triggers	VPX backplane or VPX Timing Port	VPX backplane, VPXI Timing Port	Multi-drop LVDS

GPS Interface

A GPS interface consisting of a serial port, PPS input and 10MHz reference clock input is also provided. The UART interface connects to the VPX-COMEX FPGA, which provides the interface to the host CPU. Antenna power is also provided (3.3V @ 500mA, fused). Software support for Trimble GPS units is available on the VPX-COMEX.

Custom Designs

Innovative supports customer RTM design by providing mechanical drawings, models and schematics for the RTM-COMEX.

RTM-COMEX

IMPORTANT NOTICES

Innovative Integration Incorporated reserves the right to make corrections, modifications, enhancements, improvements, and other changes to its products and services at any time and to discontinue any product or service without notice. Customers should obtain the latest relevant information before placing orders and should verify that such information is current and complete. All products are sold subject to Innovative Integration's terms and conditions of sale supplied at the time of order acknowledgment.

Innovative Integration warrants performance of its hardware products to the specifications applicable at the time of sale in accordance with Innovative Integration's standard warranty. Testing and other quality control techniques are used to the extent Innovative Integration deems necessary to support this warranty. Except where mandated by government requirements, testing of all parameters of each product is not necessarily performed.

Innovative Integration assumes no liability for applications assistance or customer product design. Customers are responsible for their products and applications using Innovative Integration products. To minimize the risks associated with customer products and applications, customers should provide adequate design and operating safeguards.

Innovative Integration does not warrant or represent that any license, either express or implied, is granted under any Innovative Integration patent right, copyright, mask work right, or other Innovative Integration intellectual property right relating to any combination, machine, or process in which Innovative Integration products or services are used. Information published by Innovative Integration regarding third-party products or services does not constitute a license from Innovative Integration to use such products or services or a warranty or endorsement thereof. Use of such information may require a license from a third party under the patents or other intellectual property of the third party, or a license from Innovative Integration under the patents or other intellectual property of Innovative Integration.

Reproduction of information in Innovative Integration data sheets is permissible only if reproduction is without alteration and is accompanied by all associated warranties, conditions, limitations, and notices. Reproduction of this information with alteration is an unfair and deceptive business practice.

Innovative Integration is not responsible or liable for such altered documentation. Resale of Innovative Integration products or services with statements different from or beyond the parameters stated by Innovative Integration for that product or service voids all express and any implied warranties for the associated Innovative Integration product or service and is an unfair and deceptive business practice. Innovative Integration is not responsible or liable for any such statements.

For further information on Innovative Integration products and support see our web site:

www.innovative-dsp.com

Mailing Address: Innovative Integration, Inc.

2390A Ward Avenue, Simi Valley, California 93065

Copyright ©2007, Innovative Integration, Incorporated