

Andalé Data Recorder



High Speed Data Recording and Playback System

FEATURES

- Turnkey, High-Speed Data Acquisition + Storage
- Internal 2 to 48 TB Hard Disk Array
- Expandable to 96 TB via external JBOD
- Up to 2400 MB/s sustained-performance from analog or digital XMC I/O module to standard Windows disk files
- Supports all Innovative X3, X5 & X6 XMC I/O module features including triggering and timing features. Log anything from RF receivers to industrial control signals.
- Rugged ATX enclosure with integrated cooling
- Autonomous or Network-controlled operation via named-pipe connections

APPLICATIONS

- High-Speed Recording/Playback
- Laboratory or factory instrumentation

SOFTWARE

- Turnkey Data Recorder software
- Supplied BinView data viewer allows rapid display and analysis of huge data sets in time or frequency domain
- Operates under Windows XP
- C/C++ API supporting custom application development
- Runs all standard XMC module application software
- Turnkey applications provided - No custom device drivers or software required

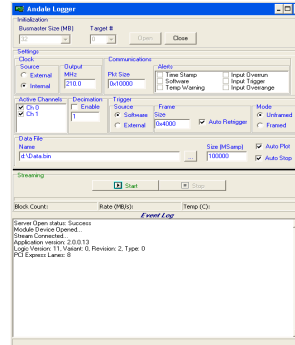

DESCRIPTION

Andalé (pronounced on'-duh-lay) is a powerful data logging system which directly controls an NTFS disk subsystem to support gap-free storage or playback of analog or digital signals acquired using the Innovative X-series XMC modules. The including logging software moves data in real-time between the analog or digital I/O peripherals on any Innovative XMC module to/from dedicated SATA drives with minimal intervention from application software or Windows.

A dedicated PCI Express RAID subsystem interfaces to conventional hard disk drives supporting guaranteed data flow rates up to 2400 MB/s, sustained. File sizes are limited only by the amount of disk storage available. Up to forty-eight terabytes of storage are available in the standard configurations; Even larger storage is supported via external JBOD enclosures. Call Innovative for details.

A multitude of analog/digital I/O interfaces are available through optional XMC modules as shown in the table below. Up to three X5/X6 or five X3-series modules may be simultaneously installed and operated in each chassis.

Please be aware that an important notice concerning availability, standard warranty, and use in critical applications of Innovative Integration products and disclaimers thereto appears at the end of this data sheet. All trademarks are the property of their respective owners.



05/06/11

PRODUCTION DATA information is current as of publication date. Products conform to specifications per the terms of the Innovative Integration standard warranty. Production processing does not necessarily include testing of all parameters.

Andalé Data Recorder



This electronics assembly can be damaged by ESD. Innovative Integration recommends that all electronic assemblies and components circuits be handled with appropriate precautions. Failure to observe proper handling and installation procedures can cause damage.

ESD damage can range from subtle performance degradation to complete device failure. Precision integrated circuits may be more susceptible to damage because very small parametric changes could cause the device not to meet its published specifications.

ORDERING INFORMATION

Product	Part Number	Description
Andalé Recording System	90036-1	Andale Turnkey Logging System including Intel i7 960-based motherboard housed in 5U Server enclosure running Windows 7, 32-bit with 6 GB DDR3 RAM, DVD drive, x16 video GPU, six available eight-lane gen2, PCIe slots, 2.4 TB, 15K RPM drive array with single gen2, PCIe RAID0 disk controller, turnkey logging software and C++ libraries for X-Series XMC modules Sustained rates of 700 MB/s or greater.
	90036-2	Same as 90036-1, except equipped with 12 TB, 7.2K RPM SATA RAID0 disk array. Sustained rates limited to 300 MB/s.
	90036-4	Same as 90036-1, except equipped with 16-SAS-drive 4.8TB array, 15K RPM RAID0 disk array. Sustained rates of 850 MB/s or greater.
	90036-6	Same as 90036-1, except equipped with 7.2 TB, 15K RPM RAID0 disk array. Sustained rates of 1000 MB/s or greater.
	90036-7	Same as 90036-1, except equipped with 1.8 TB, RAID0 disk array. Sustained rates of 500 MB/s or greater.
	90036-9	Same as 90036-1, except equipped with 19.2 TB, RAID0 disk array. Sustained rates of 1600 MB/s or greater.
	90036-8	Same as 90036-1, except equipped with 14.4 TB RAID0 disk array, dual PCIe gen 2 RAID0 controllers, yielding five available, gen2 PCIe slots. Sustained rates of 2400 MB/s or greater.
	90036-14	Same as 90036-8, except 6U enclosure equipped with 32 drive, 48 TB, RAID0 disk array.
Desktop XMC to PCIe adapter	80173-0	PCIe to XMCE Adapter Board (eight lane) for X3 or X5 modules
	80172-0	Single-Lane PCIe to XMCE Adapter Board for X3-modules only
X5-400M	80180-1	XMC module with Xilinx Virtex5 SX95, memory and 2 channels 400 MSPS, 14-bit input and 2 channels 500 MSPS DAC; 1GB/s PCIe interface
X5-210M	80190-0	XMC module with Xilinx Virtex5 SX95, memory and 4 channels 210 MSPS, 14-bit input; 1 GB/s PCIe interface
X5-GSPS	80197-0	XMC module with Xilinx Virtex5 SX95, with 2 channels 1.5 GSPS, 8-bit A/Ds, 4MB SRAM, 512 MB DRAM, PCIe interface
X3-SDF	80175-0	XMC module with Xilinx Spartan3 1M gate FPGA, memory and 4 channels of 24-bit, 5MSPS A/D
X3-10M	80192-0	XMC module with Xilinx Spartan3A DSP 1.8M gate FPGA, memory and 8 channels of 16-bit, 10 MSPS A/D
X3-25M	80176-0	XMC module with Xilinx Spartan3A DSP 1.8M gate FPGA, memory and 2 channels of 16-bit, 80 MSPS A/D, and 2 channels of 16-bit 50 MSPS DAC

Andalé Data Recorder

X3-Servo	80179-0	XMC module with Xilinx Spartan3A DSP 1.8M gate FPGA, memory and 12 channels of 16-bit, 250 ksps A/D, and 12 channels of 16-bit 2 MSPS DAC
X3-A4D4	80177-0	XMC module with Xilinx Spartan3A DSP 1.8M gate FPGA, memory and 4 channels of 16-bit, 4 MSPS A/D, and 4 channels of 16-bit 50 MSPS DAC
X3-DIO	80178-0	XMC module with Xilinx Spartan3A DSP 1.8M gate FPGA, memory and 64 bits of digital IO

Andalé Data Recorder

ABSOLUTE MAXIMUM RATINGS					
!Exposure to conditions exceeding these ratings may cause damage!					
Parameter	Min	Max	Units	Details	
Supply Voltage	+110	+230	Vac		
Supply Current	1.87	3	Amp		
Operating Temperature	15	40	C		
Storage Temperature	5	+80	C		
ESD Rating	-	1k	V	Human Body Model	

CONDITIONS					
Parameter	Min	Typ	Max	Units	Details
Forced Air Cooling	4	6	-	inches	Clearance required around unit to allow internal forced-air cooling to operate properly
Dimensions			25.2 H 9.8 W 21.1 D	inches	
Weight		75		Lbs.	

Figure 1. Andalé Block Diagram

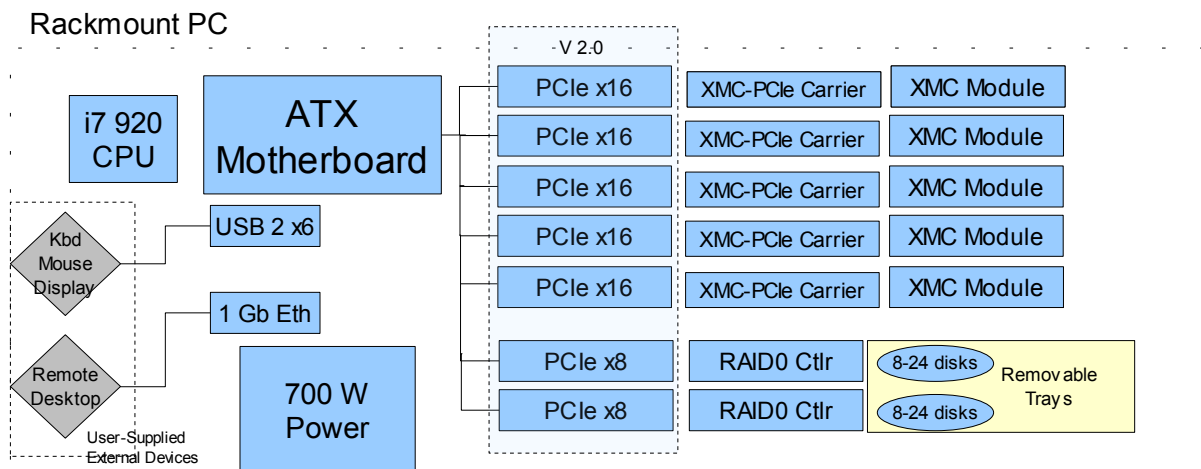

Andalé Data Recorder

Architecture and Features

Andalé is built atop the mature [Malibu Software Libraries](#), Innovative's high-performance real-time control and data acquisition framework. Malibu is written in portable C++, and uses the exceptional [Intel Performance Primitives](#) to achieve outstanding performance in the area of native signal processing and data movement on x86-class host PCs.

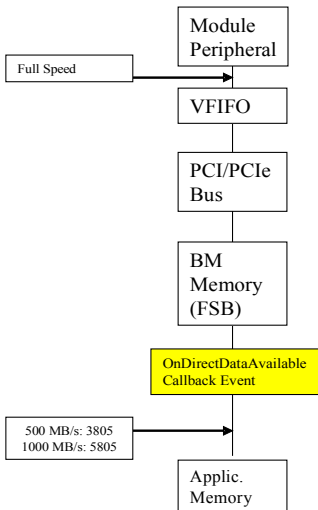

Figure 2. Block Diagram of Data Flow from XMC to Host Memory

Data flow within Andalé is illustrated in Figure 1, left. Tiered buffering insures data integrity, even under a non-deterministic operating system such as Windows XP. Analog or digital data acquired via the module peripherals flows into a large virtual FIFO implemented within on-board DDR on-module memory controlled by the FPGA firmware. 4MB, 1 GB or 4 GB of onboard FIFO memory is implemented on-module for the X3/X5/X6-series modules, respectively.

As data accumulates within the FIFO, the on-board logic automatically bus-masters data blocks into PC system memory at the maximum rate sustainable by the PCI Express interface – 200, 1200 and 2400 MB/s for the X3/X5/X6-modules respectively.

Immediately after a buffer is transferred to system memory, an interrupt routine within Malibu notifies the Andalé software subsystem, which initiates an in-place, write-to-disk operation to the RAID0 disk controller, eliminating superfluous and expensive memory copy operations.

All disk transactions are implemented using 64-bit file operations, allowing contiguous storage limited only by the size of the array. Support routines written in C++ are available to simplify access to the resulting huge data files within custom user applications.

The turnkey application software provided with Andalé supports the ability to start and stop recording in response to software commands or external signals, log up to a specified file size and to analyze data stored in standard Windows files for post-processing, meeting the most common system requirements without the need for software modification or customization.

Alternately, C/C++-savvy end-users can build a custom data logger/player application in short-order using the supplied Andalé support libraries which are compatible with Borland C++ Builder, CodeGear RAD Studio 2007 and MSVC C++ .NET 2008.

The Andalé Data Recording System combines the simple yet powerful Andalé software, a dedicated, ultra-performance SATA/SAS hard disk /controller and the Malibu Development Environment. The Malibu libraries provide full-featured support for all XMC module features, allowing users to customize the turnkey data logger source code or to create an entirely custom data recording or playback software application. Malibu has been crafted and optimized for high-speed data movement and management. It contains hundreds of reusable software building blocks (called C++ objects) which enable the user to quickly and easily perform calculations to suit a particular application. For example, components permitting optimized filtering or Fourier transformations are provided. File utilities to allow creation, editing and deletion of

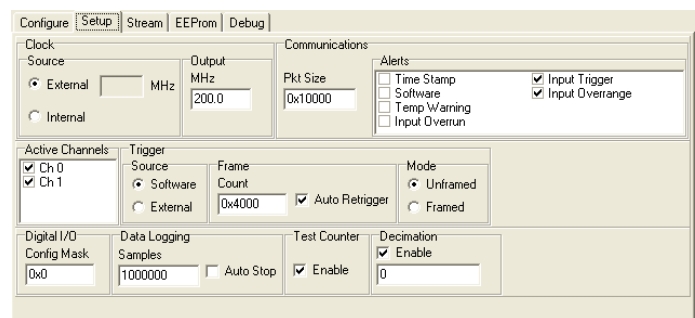

Figure 3. All module-specific configuration settings are supported

Andalé Data Recorder

the raw binary data files are also included as components.

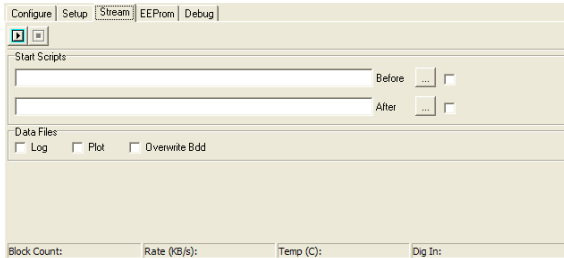

Figure 4. Data is logged in standard NTFS files, expediting analysis

The dedicated SATA RAID0 disk subsystem (call Innovative Integration for available sizes) stores the data in raw binary format to achieve the highest possible throughput (this drive should not be used as a standard Windows system drive since recording performance could be compromised). Archived data can be opened and analyzed as a standard, 64-bit Windows file for post-processing or can be viewed and analyzed in-place with the supplied raw binary data viewer, BinView, which supports graphical and tabular time/frequency-domain data display plus statistical analysis (SINAD, SFDR, THD, STDEV, MIN, MAX, etc.). Numerous Andalé library functions are supplied to facilitate in-situ analysis and conversion.

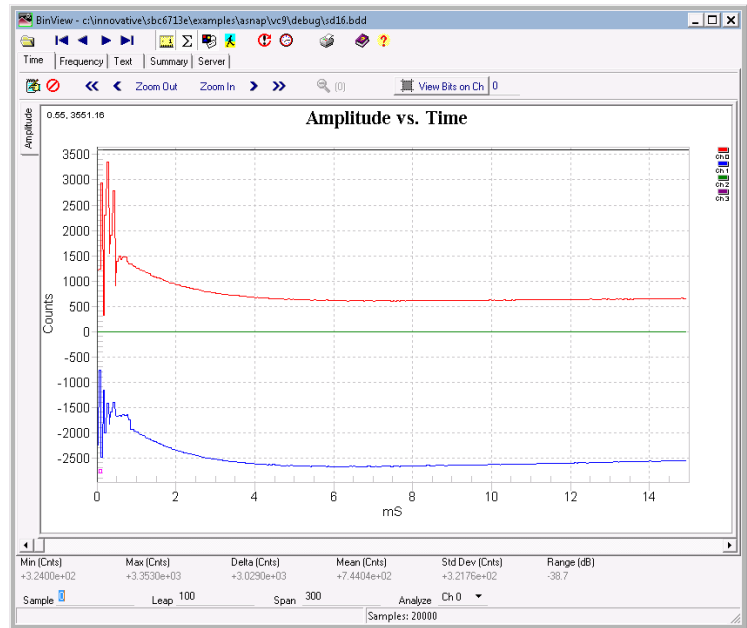

Figure 8. Binview binary file viewer applet

Andalé Data Recorder

XMC Modules

Plug XMC modules into Andalé to build your custom, turnkey data logging instrument. Innovative Integration offers an array of ultra-performance, PCI Express XMC modules to create your solution.

X5-400M - (2) 400 MSPS, 14-bit A/Ds and (2) 500 MSPS, 16-bit DACs, Virtex5 FPGA, 1GB Memory



X5 400m
PCI Express XMC Module

X5-210M - (4) 210 MSPS 14-bit A/Ds, Virtex5 FPGA, DDR2/QDR-II Memory

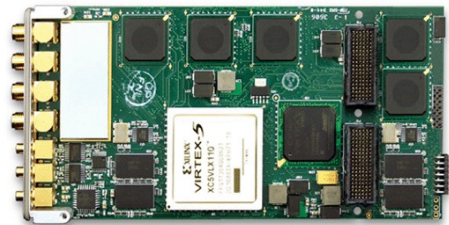

X5 210m

X3-10M - 8 simultaneous channels of 25 MSPS 16-bit A/D and 1.8M FPGA with DSP

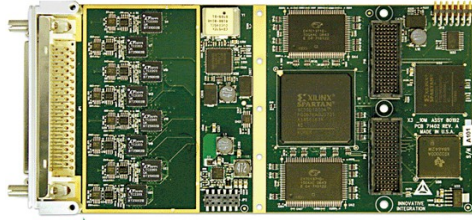

X3 10m

X3-25M - Two 25 MSPS A/Ds, Two 50 MSPS DACs and 1M FPGA

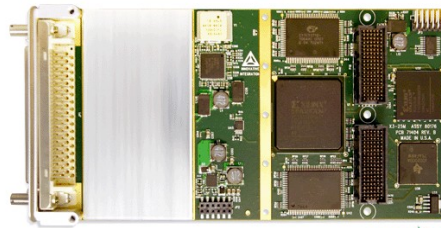

X3-SD - 16-Channels, 24-bit, 216kSPS, Simultaneous Sampling, >110 dB A/Ds, 1M FPGA and 4 MB Memory



X3 SD

X3-SDF - 4-Channels of 24 bit, Fast Sigma-Delta A/D >110 dB, 1M FPGA, 4 MB Memory

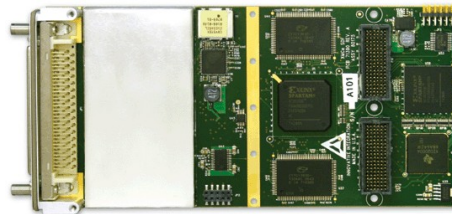

X3 SDF

Andalé Data Recorder

Module Carriers

XMC modules are electrically-equivalent to standard desktop PCI Express cards. However, they adhere to the PMC module rather than the standard desktop PCIe card mechanical specifications. Consequently, use of one of the adapter cards listed below is required to allow use of an XMC module within the ATX motherboard within the Andalé chassis.



Figure 5. Optional 1-Lane XMC to PCI Express Adapter Card, P/N 80172-0



Figure 6. Optional 8-Lane XMC to PCI Express Adapter Card, P/N 80173-0



Figure 7. Optional 8-Lane XMC to PCI Express Adapter Card, P/N 80259-0

The 1-lane adapter should be preferred whenever using X3-series modules, since the Andalé motherboard features three one-lane slots. However, the 80173/80259 8-lane adapter should be used when using X5/X6-series modules respectively, in order to achieve rated throughput.

Andalé Data Recorder

IMPORTANT NOTICES

Innovative Integration Incorporated reserves the right to make corrections, modifications, enhancements, improvements, and other changes to its products and services at any time and to discontinue any product or service without notice. Customers should obtain the latest relevant information before placing orders and should verify that such information is current and complete. All products are sold subject to Innovative Integration's terms and conditions of sale supplied at the time of order acknowledgment.

Innovative Integration warrants performance of its hardware products to the specifications applicable at the time of sale in accordance with Innovative Integration's standard warranty. Testing and other quality control techniques are used to the extent Innovative Integration deems necessary to support this warranty. Except where mandated by government requirements, testing of all parameters of each product is not necessarily performed.

Innovative Integration assumes no liability for applications assistance or customer product design. Customers are responsible for their products and applications using Innovative Integration products. To minimize the risks associated with customer products and applications, customers should provide adequate design and operating safeguards.

Innovative Integration does not warrant or represent that any license, either express or implied, is granted under any Innovative Integration patent right, copyright, mask work right, or other Innovative Integration intellectual property right relating to any combination, machine, or process in which Innovative Integration products or services are used. Information published by Innovative Integration regarding third-party products or services does not constitute a license from Innovative Integration to use such products or services or a warranty or endorsement thereof. Use of such information may require a license from a third party under the patents or other intellectual property of the third party, or a license from Innovative Integration under the patents or other intellectual property of Innovative Integration.

Reproduction of information in Innovative Integration data sheets is permissible only if reproduction is without alteration and is accompanied by all associated warranties, conditions, limitations, and notices. Reproduction of this information with alteration is an unfair and deceptive business practice.

Innovative Integration is not responsible or liable for such altered documentation. Resale of Innovative Integration products or services with statements different from or beyond the parameters stated by Innovative Integration for that product or service voids all express and any implied warranties for the associated Innovative Integration product or service and is an unfair and deceptive business practice. Innovative Integration is not responsible or liable for any such statements.

For further information on Innovative Integration products and support see our web site:

www.innovative-dsp.com

Mailing Address: Innovative Integration, Inc.

2390A Ward Avenue, Simi Valley, California 93065

Copyright ©2007, Innovative Integration, Incorporated