

DR PMC/XMC

16-Channel Wide Band Receiver
125 MSPS Sampling
GC5016 Digital Down Converters
Xilinx Virtex2 Pro FPGA for User Code

Features

Four LTC2255, 14-bit, 125 MSPS A/D converters

Virtex-II Pro FPGA, 4 Million gates

PCI 64/66 with P4 port to host card

64MB SDRAM plus 2MB RAM for FPGA

Low-jitter PLL clock source

Advanced SW and firmware demo programs

XMC - 8Gbps full duplex

Applications

Software Defined Radio (SDR)

Signal Identification

Electronic Warfare

Advanced RADAR

Hardware Testing

Telecom IP development



Ordering Information

| | |
|--------------------------|---------|
| DR PMC Module w/4 GC5016 | 80123-0 |
| DR PMC Module | 80123-1 |



Overview

The DR Digital Receiver PMC card features four 125 MSPS, 14-bit A/Ds with 16 digital receiver channels and an FPGA processing core. It integrates the latest analog chips with a 4M Virtex-II Pro FPGA for user-code, ample memory and flexible clocks/triggers on a 64/66 PCI mezzanine format.

High speed digital signal processing algorithms in the FPGA are developed using MATLAB and VHDL code. The FPGA Framework logic allows quick integration of custom signal processing into the data flow of the module through use of component-based modular design. DSP algorithms are rapidly designed using high-level MATLAB simulations that can be integrated into the FPGA hardware with minimal VHDL coding.

Novel features include on-board low jitter PLL clock, Sync Burst RAM dedicated to FPGA for fast, block-oriented processing and a direct PMC J4 DIO connection to the host card. The J4 and XMC interfaces offer a very high-rate, low latency connection to Innovative Integration's Velocia series of DSP and FPGA compact PCI boards and this port protocol can be reconfigured in logic to communicate with third party host cards.

Description

The front-end features four analog input channels consisting of 350 MHz input bandwidth, 50-ohm single-ended input followed by a 125 MSPS, 14-bit Linear Technology LTC2255 A/D converter. The converter clock can be either the highly accurate PLL device ranging from 31MHz to 200MHz with a 3 pico-second RMS jitter, or the user can provide external clocks for conversion or PLL reference.

Four TI/GrayChip GC5016 Digital Down Converters have their input and output connected to the user-FPGA. This allows for the most flexible signal path, as each individual signal chain can be defined in logic. The GC5016 is a flexible wideband 4-channel digital up-converter and down-converter. In down-conversion mode, the channel accepts real or complex signals, demodulates them from selected carrier frequencies, decimates them by programmable amounts ranging from 1 to 4096, applies a gain from a user defined automatic gain control, and produces 12 to 20-bit outputs. The frequencies and phase offsets of the four sine/cosine sequence generators can be independently specified, as can the interpolation and filtering of each circuit. Channels can be synchronized to support beam forming or frequency hopped systems. The output from the down-conversion channel is formatted and output in up to four output ports as either real or complex data.

The DR Digital Receiver PMC card shares a common architecture with numerous other VelociaPMC cards including PCI interface, XMC support, clocking and memory.

The "application-FPGA" is a 4-million (XC2VP40) gate device of Xilinx Virtex-II Pro family and is virtually 100% available for user-code. Ample resources allow for flexible integration of the most demanding signal processing blocks such as down/up conversion, complex filtering, resampling, spreading/despreading and signal analysis. For example, the Xilinx DDC logic core for GSM consumes only 1373 slices (< 10K gates) and 1 multiplier.

The application-FPGA controls the I/O, the PLL time base, triggers, 64MB of DDR SDRAM for large data buffering, and a dedicated 2MB SBSRAM. The SDRAM memory is available to the FPGA as a data buffer or for use by the PowerPC processors. The Framework Logic shows an example of using the memory as a very large FIFO for the data channels.

The application FPGA also provides a direct interface to host cards using the PMC J4 or XMC for a private data/control path that can provide a data pipe bandwidth of up to 800MB/s between logic, host and external hardware with Innovative Integration's Velocia DSP and FPGA cPCI boards and other off-the-shelf host cards.

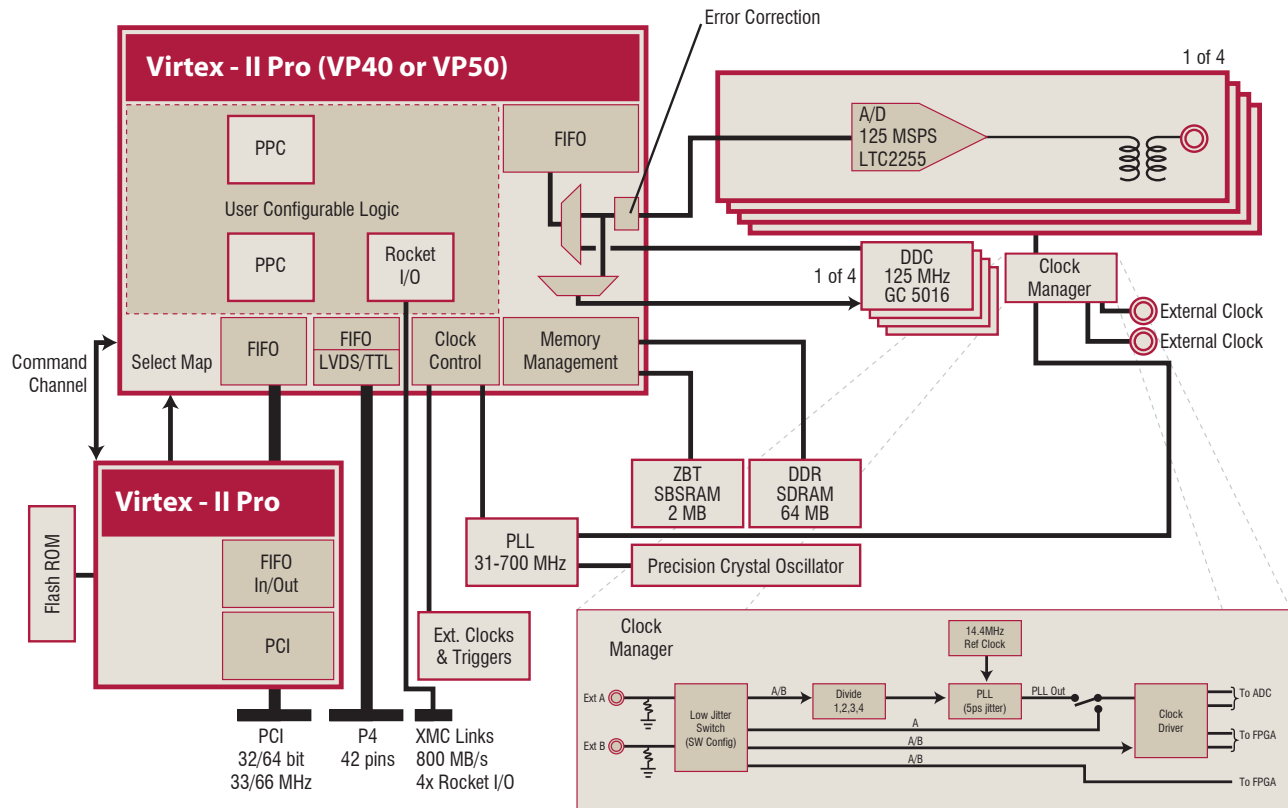

The application FPGA is tied to the PCI interface chip using 2 Rocket IO links, for a 4 Gbps full duplex maximum data rate. The 64/66 PCI interface supports a sustained data rate of 450 MB/s to system memory. An efficient packet protocol with credit-based flow control allows the PMC to support both high sustained rates of data and a flexible communication path to the host.

Firmware for the application FPGA can be configured dynamically via SelectMap, controlled over the PCI bus with the turnkey utilities with software source code provided.

Software and Logic Framework – Custom Logic Support

The DR Digital Receiver PMC offers a 4M gate FPGA for custom code implementation. Innovative Integration provides source code of the logic blocks implemented on the card as delivered and demonstrating hardware functionality: front-end A/D and receiving FIFOs, as well as the DDC converters, PLL time base control, DDR SDRAM control, SBSRAM controller, J4 interface and interface to the PCI-FPGA.

Logic development is supported using either VHDL and/or MATLAB. VHDL source files as well as test bench files for ModelSim are provided. Examples also demonstrate use of Xilinx System Generator for MATLAB into the Framework logic. Development is supported using Xilinx ISE, XST VHDL, with simulation under Mentor Graphics ModelSim.

MATLAB Simulink, in conjunction with Xilinx System Generator may be used for logic development. This powerful graphical tool set allows the signal processing designer to develop algorithms using all the power and grace of MATLAB and then implement them directly in logic. The DR Board Support Package (BSP) provides blocks for the hardware interface ready to use in the Simulink graphical design environment. Gateways to MATLAB allow the developer to quickly test the system by using Simulink to generate, analyze and display the actual data on the hardware during design. Nothing could be easier for advanced signal processing development!

Go directly from MATLAB into the GC5016 using our application software and MATLAB models for the downconversion and filtering design. Once the design is modelled in MATLAB, the design can be put into the GC5016 without any additional coding.

- PMC DR MATLAB Examples
- A/D and DDC with DDR Buffer
 - Capture A/D to SRAM
 - Downconversion
 - SRAM Use
 - User Example

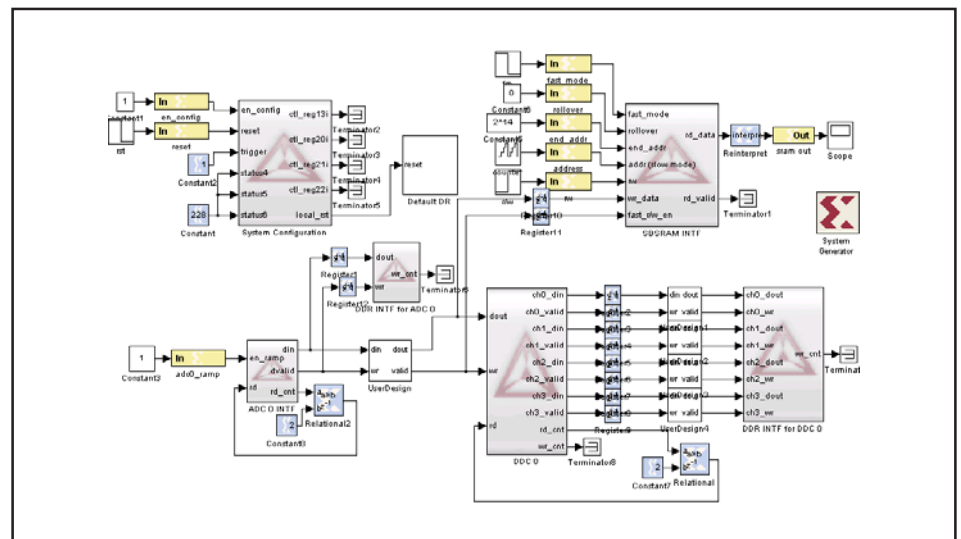

PCM DR Logic Development using MATLAB

DR Velocia PMC/XMC Module

The PCI-FPGA is not intended for end-user logic development and source code is usually not provided. Contact Innovative Integration if your application might require changes to these specific interfaces.

Software Support

Innovative Integration's software tool kit for the VelociaPMC series is a powerful collection of software libraries, utilities, examples projects and interactive help file that allow developers to be very productive from the start. Numerous program examples - with source code- demonstrate the usage or every peripheral on the board and provide a framework for further custom development.

An application allowing the DR to collect data is provided as an out-of-the-box application for evaluation and as a software example.

OEM Configurations

The DR VelociaPMC board can be configured or modified to fit your specific requirements and provide an optimal mix of performance, cost and features. Contact Innovative Integration with your specific OEM requirements.

Analog Performance Characteristics

Intermodulation Distortion 4.9 & 5.1 MHz

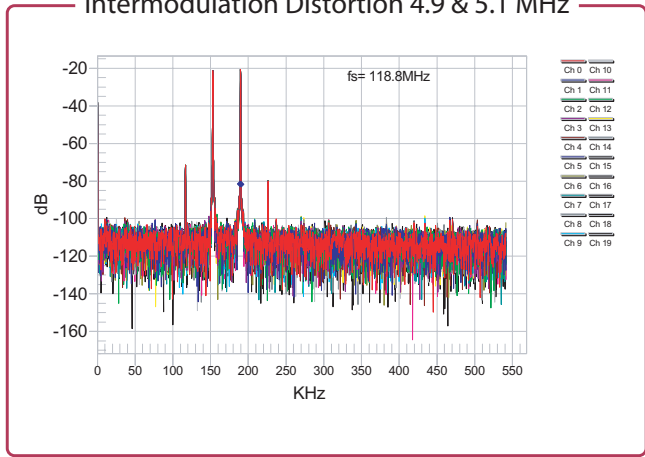

Crosstalk

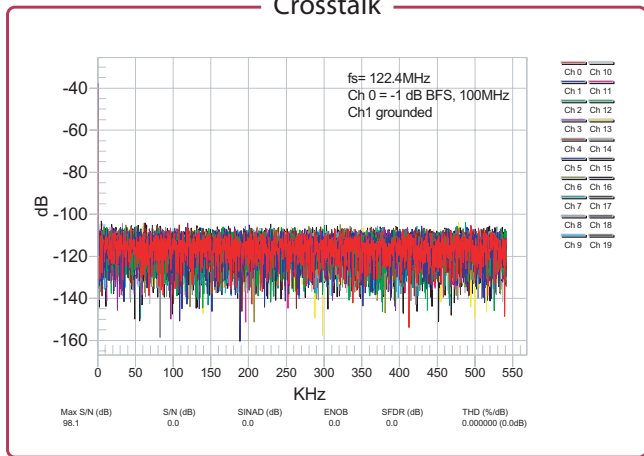

Signal Quality

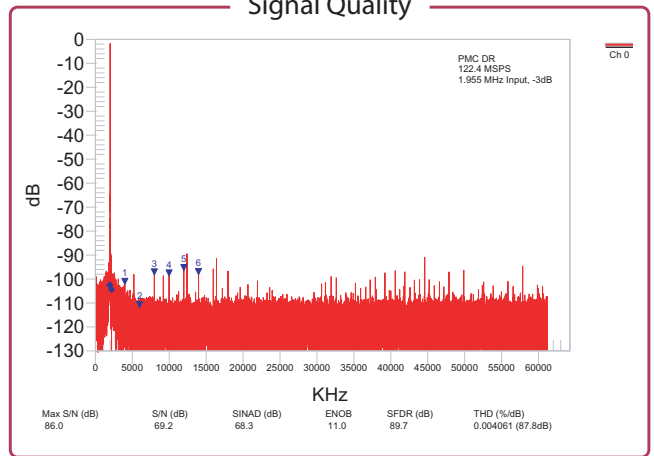

Velocia PMC Modules

Signal Quality @ 10MHz

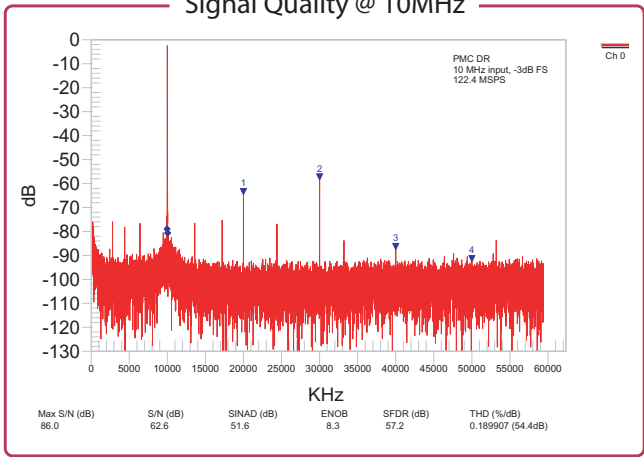

Signal Quality @ 100MHz

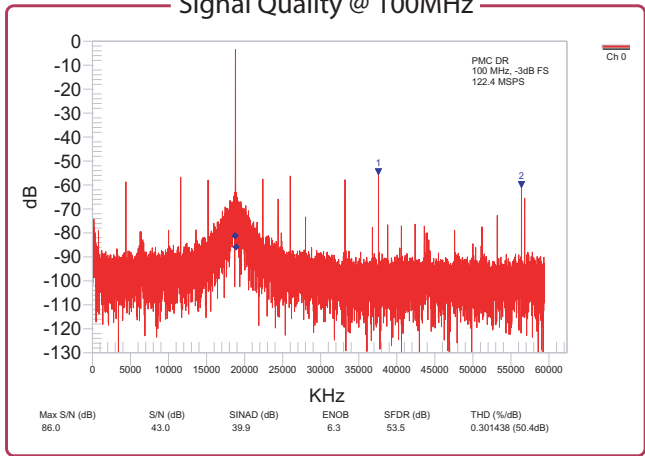

Signal Quality @ 350MHz

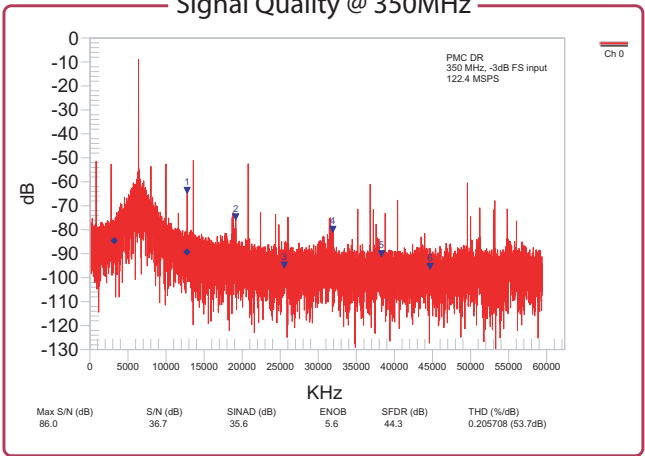

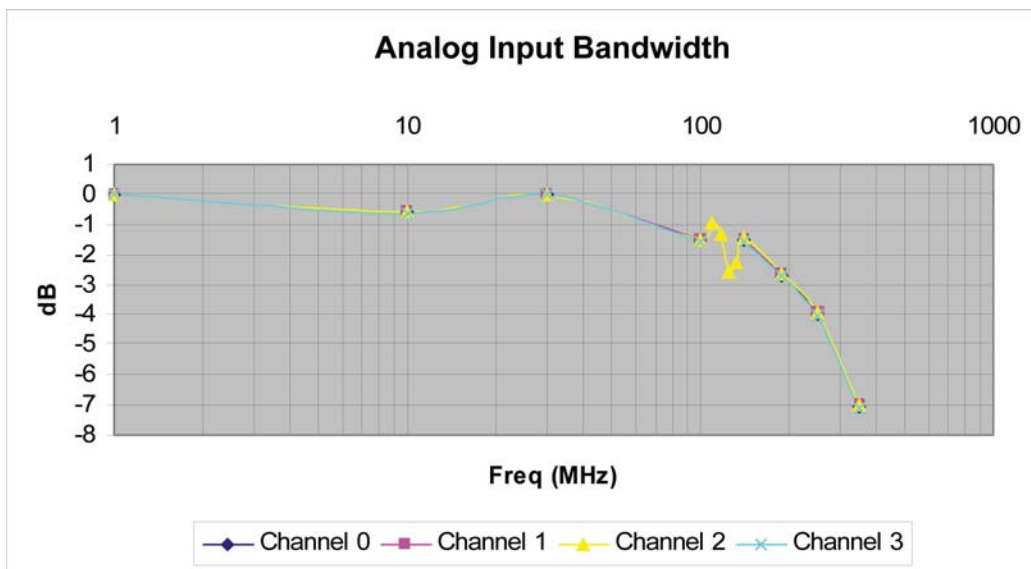
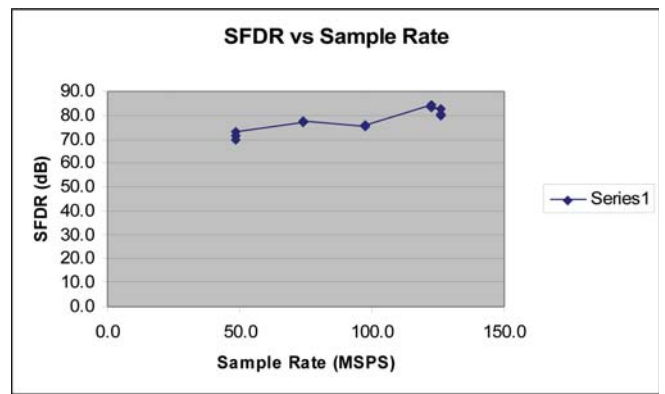
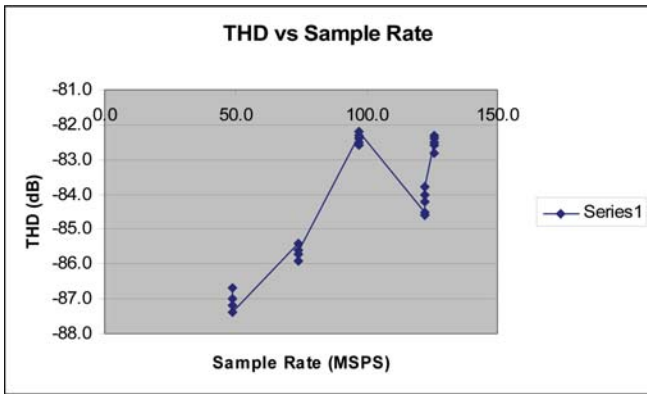
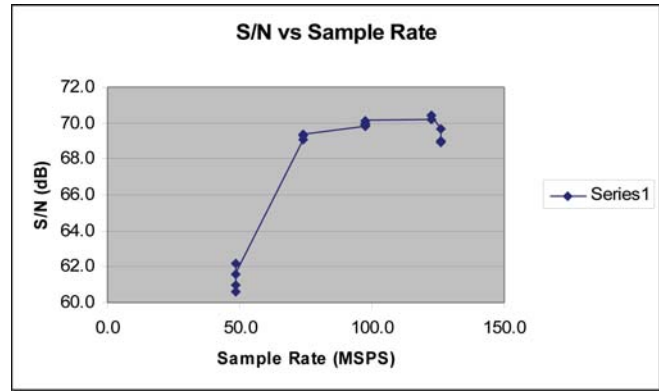
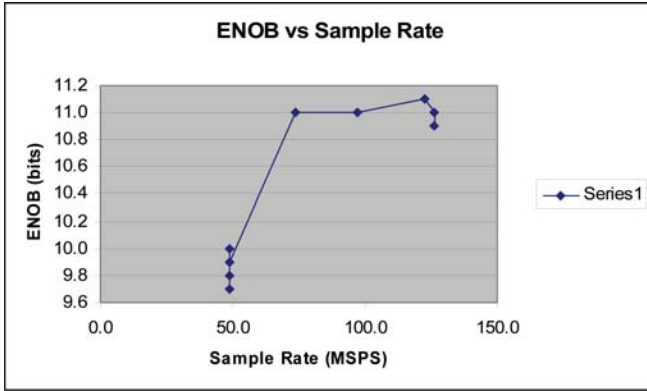

Analog Input

4 Independent Analog Input
 50 Ohm Impedance
 Single-ended
 AC coupled
 350 MHz input bandwidth
 Range 2.3Vpp

Analog IO Performance

14-bit A/D Converter Linear Technology LTC2255
 Sampling Rate: 15-125MSPS (decimation supported for lower rates)
 Digital gain/offset correction in logic
 All specifications at 25C

DC Specifications

| | |
|-----------------|------------------------|
| Offset Error | Calibrated to <1 mV |
| Gain Error | Calibrated to <0.5% FS |
| Linearity Error | <1.5 LSB |

AC Specifications

| | |
|-----------------------------|--------------------------|
| 1.955 MHz input, 122.4 MSPS | |
| SFDR | 89 dB |
| ENOB | 11.2 bits |
| S/N | 70.7 dB |
| Crosstalk | -93.5 dB (100 MHz input) |
| Analog In Bandwidth | 200 MHz (-3 dB) |

Digital Down-Converters

16 channels of digital receiver
 Four Texas Instruments GC5016 chips
 Accepts real or complex signals
 Decimate by 1 to 4096
 User-selectable Gain
 Up to 20-bit output
 Adjustable Freq/Phase Offset on mixer
 Adjustable interpolation and filter
 Supports Channel Synchronization
 Outputs real or complex

Time Base and Triggers

Software selectable timebase:
 PLL, external input A or B
 PLL using 14.4 MHz precision crystal or external timebase divided by 1,2,4,8, or 16.
 (4) timebases may be used:
 PLL reference clock range: 10 to 25 MHz
 (2) external on 50 ohm SMBs
 PLL capable of 30-700MHz
 Triggering using external input or software (may be modified in custom logic)
 External clock requirements
 800 mV p-p minimum, 0.6 to 1.4V maximum input -0.1V to 3.4V
 (2) External clock inputs on 50 Ohm SMB external sync signal

Application-Configurable Logic

Xilinx Virtex2 Pro XC2VP40
 XC2VP40-5FF1152C (standard, faster speed grades and larger VP50 may be custom ordered.)
 FPGA Fabric :
 4 Mgate (approx.)
 192 hardware multipliers
 3456 Kb embedded FPGA RAM
 Two PowerPC
 (4) Rocket IO links using XMC, 10 Gbps full duplex, 2.5 Gbps full duplex each
 SelectMAP loading from PCI bus
 Direct connect to XMC-4 lanes 2Gbps full duplex
 VHDL source code with ModelSim test benches
 JTAG port for download and ChipScope
 J4 connector 42 pins connect to PMC host (RACE++ pinout) to PMC host

PCI-FPGA

Xilinx Virtex2 Pro VP4
 Supports PCI interface
 Loads from field reprogrammable FLASH memory

Memory

64 MB DDR SDRAM (call for larger options)
 2 devices configured as 16M x 32 bits, clocked at up to 150 MHz
 80 MHz minimum clock rate
 2 MB ZBT SBSRAM
 Organized as 1Mx16
 Clock at up to 167 MHz
 Usable either as FPGA memory or PowerPC memory
 FrameWork Logic provides firmware for DRAM use as FIFO buffer

XMC

VITA 42.0 compatible
 4 lanes of Rocket IO
 2 Gbps per lane standard, full duplex
 Directly attached to application FPGA
 800 MB/s aggregate rate, full duplex

PCI Interface

64-bit, 66 MHz, 3V
 Down-selects to 32 bit and 33MHz if needed
 Packet protocol
 Supports 32 data channels
 4kB FIFO in each direction
 450 MB/s sustained data rate to memory 64bit, 66 MHz PCI (tested on Intel Server Board SE7520BD2)
 >60 MB/s sustained data rate on most 32-bit, 33 MHz desktop systems

Debug Ports

JTAG for FPGA:
 Xilinx standard 14-pin, 2mm header compatible with Xilinx cables
 38 pin MICTOR compatible with many logic analyzers from application logic (optionally installed)

Connectors

SMB 50ohm for Ext Clocks and Sync
 SMA 50ohm for analog inputs

Power

11.7W total for FrameWork Logic
 3.3V @ 1.9A, 5V @ 1.6A typical
 Power consumption varies with application logic.

Operating Conditions

0-55°C, non-condensing
 Forced air: minimum 1 cubic ft/min forced air required
 Designed to meet ETS 300 019-1.1 Class 1.2, ETS 300 019-1.2 Class 2.3, ETS 300 019-1.3 Class 3.3

Development Languages

Logic

VHDL with Xilinx ISE, Mentor Graphics ModelSim, MATLAB and System Generator
 Malibu Toolset includes libraries, projects, utilities, help files

Host PC

MS Visual C++ , .NET, Borland C++ Builder,

Application Software

Data logging and demonstration application (WinXP/2000)
 MATLAB project for DDC Design.

Physicals

IEEE 1386 compliant
 Single Width PMC/XMC card
 74 x 149 mm
 Weight : 0.13kg (0.06 lb)
 10mm spacing to host card

Accessories

SMB-BNC cable, 1M, P/N 67021

Documentation

DR Hardware user Guide
 FrameWork Logic User Guide
 Malibu Software Development Manual
 MATLAB BSP Manual

Environmental Data

Lead Free
 ROHS compliant