

PCIe-XMC x8 Adapter

Adapts XMC Module to desktop x8 PCIe slot with up to Gen 3 speed

V1.1 06/09/20

FEATURES

- Adapts one XMC PCI Express VITA 42.3 module to a desktop PCI Express slot
- Supports up to 8 PCIe lanes
- High speed expansion port from XMC P16 connector available via a Dual MiniSAS HD type connector or two QSFP ports when used with an optional Satellite board
- 8 differential DIO signal pairs from XMC P16 routed to the DIO connector on the bracket
- IEEE 1386 XMC mechanicals
- Configurable XMC VPWR options
- Auxiliary power connector for VPWR (External Power option)
- Can be used with VPWR = +5V with the auxiliary power connector
- Clean +3.3V on-board power supply for low-noise XMC module operation
- On-board input voltage monitor/sequencer for XMC module protection
- Robust thermal solution allows effective cooling of the high power dissipating XMC modules
- On-board USB to JTAG programmer allows XMC module FPGA programming via the P15 connector
- 14-pin JTAG header with Xilinx compatible pinout is also provided
- XMC Module Voltage and Current Test header
- 3-Bit Geographic Address DIP switch
- External Clock, Trigger and 1 PPS RF SSMC type connectors
- ~2/3 full length PCI Express card
- Occupies two adjacent slots in the system (one must be PCIe x8 or x16 slot; no connections on the second slot)
- Satellite board requires single x1 PCIe slot

APPLICATIONS

- Add XMC modules to standard PCIe host systems
- System expansion using high speed serial links

SOFTWARE

- No software required for normal operation
- Software required for the USB JTAG Programmer operation is available free of charge from Xilinx and Digilent

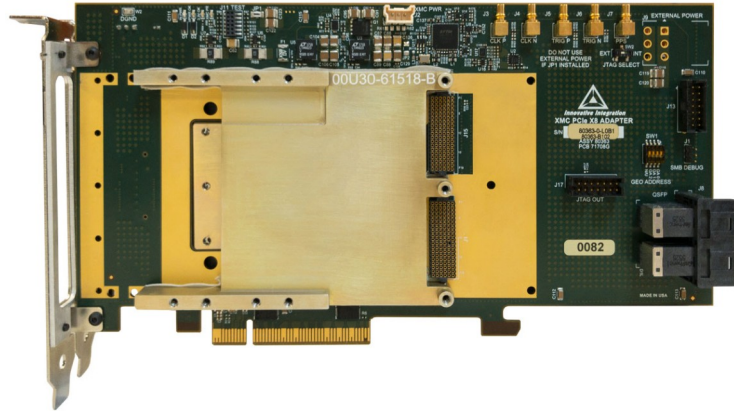

DESCRIPTION

The XMC module to PCI Express Adapter (“Adapter”) allows a single width XMC VITA 42.3 compatible module to be used in a PCI Express x8 or x16 slot. By using the high quality low loss PCB material and the best layout practices for maintaining highest possible signal integrity up to Gen 3 PCIe speed operation is possible. However, the PCIe link maximum speed is dependent on the used XMC module / host system combination and cannot be guaranteed by Innovative.

The XMC P16 connector’s eight high-speed signal pairs, which are typically connected to the Multi-Gigabit Transceivers (MGT) on the XMC module’s FPGA, are routed to a dual Mini SAS HD SB type connector and, with an optional XMC-PCIe x8 Adapter Satellite Board (“Satellite Board”), provide user with two high-speed QSFP ports. This allows for a simple way to “patch-panel” communications links between cards and or/other systems. A direct board to board connection without the Satellite board is also possible when two Adapter boards are used inside the same host system. When operating with most Innovative XMC modules speeds up to 3Gbps are typically achievable.

Please be aware that an important notice concerning availability, standard warranty, and use in critical applications of Interconnect Systems International, LLC, Inc. products and disclaimers thereto appears at the end of this data sheet. All trademarks are the property of their respective owners.

PRODUCTION DATA information is current as of publication date. Products conform to specifications per the terms of the Interconnect Systems International, LLC, Inc. standard warranty. Production processing does not necessarily include testing of all parameters.

PCIe-XMC x8 Adapter

Eight differential matched-length signal pairs are routed from the XMC P16 to the high-speed DIO (Digital Inputs/Outputs) connector. These signals are usually connected to one of the FPGA banks on the XMC module and used general purpose DIO-s. A twinax high-speed cable and a breakout board are available from Innovative to use with DIO signals. Special support for trigger, clock and timing signals for Innovative XMC modules is provided through five SSMC type coaxial connectors.

The adapter has the on-board USB JTAG programmer circuitry allowing in-system programming of the XMC module's FPGA via the XMC P15 (if supported by the XMC module) and eliminating the need to use a special external JTAG programmer. A mini-USB connector with a standard USB 2.0 Type A to Micro USB male cable is used for the host USB port connection. Software required for this circuit operation is available free of charge from Digilent and Xilinx. A Xilinx compatible 14-pin JTAG header is also provided and can be used if for some reason it is preferable to use an external JTAG programmer. A mini-DIP switch SW2 on the Adapter board lets user to select internal or external JTAG programmer mode of operation.

Board also has a 14-pin JTAG output header to use with XMC modules which do not have JTAG signals routed to the P15 connector. A 14-pin Xilinx programmer compatible flat ribbon cable available from Innovative or other vendors can be used to connect the Adapter JTAG output to the XMC board's JTAG header.

Geographic Address DIP switches can be used for the XMC module unique identification inside the host system. This is especially valuable when more than a single module of the same type is used inside the host system.

A highly efficient low EMI DC-DC converter capable of providing up to 6A of current generates +3.3V DC voltage rail for the XMC module from the input VPWR (+12V or +5V). The adapter has an on-board power sequencer and monitoring circuitry which controls the XMC module's power-up and power-down sequences and ensures that the XMC module's VPWR and +3.3V power rails are within the allowed limits.

The Adapter utilizes a flexible power scheme. In standard configuration VPWR = +12V and it comes from the host system via the PCIe edge connector. This configuration allows XMC modules to consume up to 75W when plugged into a high-power capable PCIe slot (such as a slot intended for graphics applications). More power to the XMC module may be provided by using the optional 6-pin auxiliary power connector J9 on the Adapter board instead of the PCIe edge connector. It is also possible to use +5V for VPWR instead of +12V with the J9 connector. In this case jumper JP1 must be removed to avoid the short connection between the host's +12V rail and the external +5V power supply. Other power configurations are possible; this can be done by changing the stuffing of the high-current jumper resistors on the adapter board; contact Innovative support for further information.

A direct connection from the host system to the XMC connector is provided for the 3.3VAUX power rail. In standard configuration the optional XMC +12V Auxiliary power input is connected to the main VPWR (+12V) power rail; -12V rail is not powered. It is however possible to use an external power supply to provide -12V voltage to the XMC module utilizing the J2 connector on the main adapter board.

The Adapter passes SMBus signals from host to the XMC module. The J1 connector on the main board can be used for debugging and monitoring the SMBus operation.

The Adapter has a voltage and current test header J11 located on the main board allowing user to monitor the XMC module's voltages and currents on both VPWR and +3.3V rails.

Four LED-s on the Adapter board are used as the power status and the XMC module presence indicators.

An enhanced heatsink with high CFM airflow fans provides highly efficient cooling to the XMC module. Innovative offers customized XMC heatsink options to use with the XMC-PCIe Adapter board and Innovative XMC modules. Conduction cooling according to VITA20 standard is optional.

PCIe-XMC x8 Adapter

The XMC module mounts securely to the adapter using standoffs. The XMC bracket mates to standard PMC end brackets and supports an EMI gasket.

Mechanically the adapter is built as an ~2/3 full size PCIe card. A small DIO board is plugged into the main board via a high-speed connector and provides user access to DIO signals via a 26-pin high-speed connector J1; a micro USB connector J2 used for the USB JTAG programmer circuitry. The Adapter occupies 2 slots in the host system; one slot must be x8 (or x16) PCIe capable; no electrical and mechanical connections are needed on the second slot so it can be either PCI or PCIe type.

The Adapter does not support the XMC JN4 connections; however an XMC module with installed JN4 connector can be plugged into the Adapter without causing mechanical interference.

The optional Satellite board can reside anywhere in the host system; it requires a single x1 PCIe slot for operation. Note that the Satellite board uses only the +3.3V power from the slot it's plugged into; it does not enumerate on PCIe bus in the host system because there is no connection to the host's PCIe bus. The Satellite board receives high-speed serial link signals from the Adapter board along with the low speed control signals via two MiniSAS HD SB type cables. The Satellite board outputs the serial link signals in the form of two standard QSFP type connectors accessible from the Satellite board's bracket.

All high-speed signal pairs on the Adapter and Satellite boards, including user accessible DIO-s, are routed with 50 Ohm single ended / 100 Ohm differential characteristic impedance suitable for high-speed signaling standards such as LVDS, PECL or similar.



This electronics assembly can be damaged by ESD. Interconnect Systems International, LLC recommends that all electronic assemblies and components circuits be handled with appropriate precautions. Failure to observe proper handling and installation procedures can cause damage.

ESD damage can range from subtle performance degradation to complete device failure. Precision integrated circuits may be more susceptible to damage because very small parametric changes could cause the device not to meet its published specifications.

PCIe-XMC x8 Adapter

ORDERING INFORMATION

Product	Part Number	Description
XMC-PCIe x8 Adapter	80363-0-L0	XMC-PCIe x8 ADAPTER – X6 High Heat – Internal Power
XMC-PCIe x8 Adapter	80363-1-L0	XMC-PCIe x8 ADAPTER – X6 High Heat – External Power
XMC-PCIe x8 Adapter	80363-2-L0	XMC-PCIe x8 ADAPTER – XMC Standard – Internal Power
XMC-PCIe x8 Adapter	80363-3-L0	XMC-PCIe x8 ADAPTER – XMC Standard – External Power
XMC-PCIe x8 Adapter	80363-4-L0	XMC-PCIe x8 ADAPTER – XU High Heat – Internal Power
XMC-PCIe x8 Adapter	80363-5-L0	XMC-PCIe x8 ADAPTER – XU High Heat – External Power
XMC-PCIe x8 Adapter Satellite Board 2.5V DIO	80369-0-L0	XMC-PCIe x8 Adapter Satellite Board with two 67234 cables, 2.5V DIO levels
XMC-PCIe x8 Adapter Satellite Board 1.8V DIO	80369-1-L0	XMC-PCIe x8 Adapter Satellite Board with two 67234 cables, 1.8V DIO levels
XMC-PCIe x8 Adapter Satellite Board Basic High-Speed Link Support	80369-2-L0	XMC-PCIe x8 Adapter Satellite Board with two 67238 cables, Basic High-Speed Link Support
MiniSAS HD cable with SB	67234	CABLE ASSY MINI SAS HD 36 PIN M-M W/SB INT 0.5M
MiniSAS HD cable without SB	67238	CABLE ASSY MINI SAS HD 36 PIN M-M WO/SB INT 0.5M
Breakout Board (no cable)	80365-0-L0	DIO 2X13 TWINAX BREAKOUT BOARD, NO CABLE
Breakout Board (with 12" Twinax Cable)	80365-1-L0	DIO 2X13 TWINAX BREAKOUT BOARD, 12 INCH CABLE
Breakout Board (with 24" Twinax Cable)	80365-2-L0	DIO 2X13 TWINAX BREAKOUT BOARD, 24 INCH CABLE
Breakout Board (with 36" Twinax Cable)	80365-3-L0	DIO 2X13 TWINAX BREAKOUT BOARD, 36 INCH CABLE
12" Twinax Cable	67235	Cable Assy, DIO 2x13 Twinax w/Squeeze Latch both ends, 12"
24" Twinax Cable	67236	Cable Assy, DIO 2x13 Twinax w/Squeeze Latch both ends, 24"
36" Twinax Cable	67237	Cable Assy, DIO 2x13 Twinax w/Squeeze Latch both ends, 36"
6" Flat Ribbon Cable, 14-position	67245	Cable Assembly Ribbon Cable, JTAG, 28AWG 14POS IDC Connector SKT

Note: Please contact Innovative support if you need help with your ordering options.

PCIe-XMC x8 Adapter

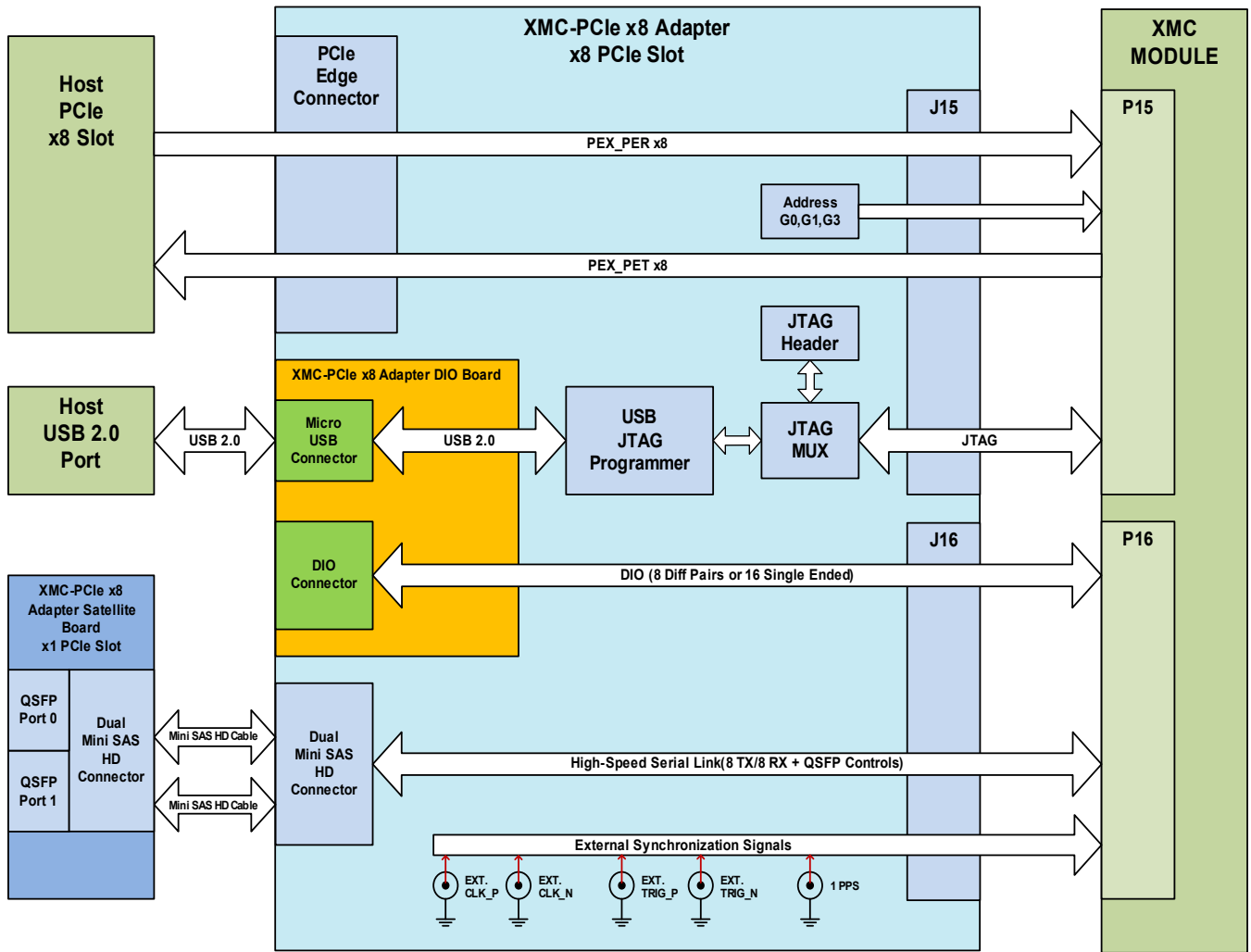

Figure 1. XMC-PCIe x8 Adapter Block Diagram

PCIe-XMC x8 Adapter

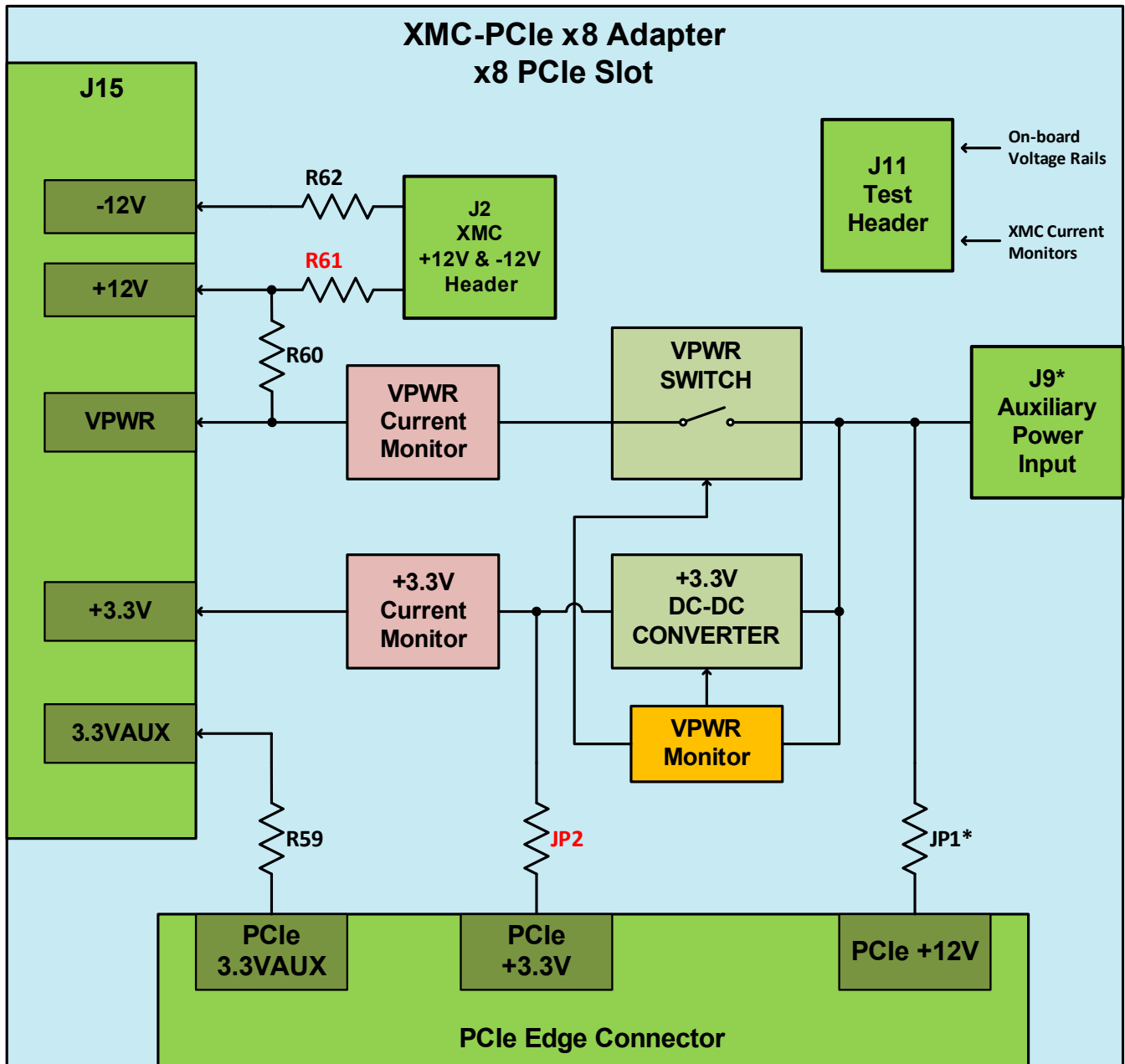

Figure 2. XMC-PCIe x8 Adapter Power Connections Diagram

PCIe-XMC x8 Adapter

Notes:

1. In 80363-0-L0, 80363-2-L0 and 80363-4-L0 (Internal Power) configurations jumper JP1 is stuffed and connector J9 is unstuffed. VPWR is supplied from the host +12V rail via the PCIe Edge Connector.
2. In 80363-1-L0, 80363-3-L0 and 80363-5-L0 (External Power) configurations jumper JP1 is unstuffed and connector J9 is stuffed. VPWR is supplied from the Auxiliary Power connector J9.
3. In all standard configurations JP2 and R61 are unstuffed, so the +3.3V to XMC is generated on the Adapter board and the XMC +12V Auxiliary power input is connected to VPWR. The XMC Auxiliary -12V rail is supported only via the external J2 connector.

Physicals	
Form Factor	PCI Express ~2/3 Full Size card, 2 adjacent slots are required
Size	111.15 mm x 207.50 mm (4.375 in x 8.17 in)
Weight	~150g (without fan/heatsink)

Power Capability Delivered to the XMC	
Voltage	Note
3.3V	6A Maximum, generated on-board from VPWR
VPWR	Supplied by the host (+12V) or from the J9 Auxiliary Connector (in this case jumper JP1 must be removed and the +5V VPWR operation is possible).
+12V	Connected to VPWR in all standard configurations. Can be also supplied from the connector J2 externally (in this case resistor R61 must be removed).
-12V	Must be provided from the connector J2 externally if needed
3.3VAUX	Supplied by the host

PCIe-XMC x8 Adapter

Applications Information

Power to the XMC Module

The Adapter has a flexible XMC module powering scheme. In all Internal Power options (80363-0-L0A, 80363-2-L0A and 80363-4-L0A) the PCIe +12V from the PCIe edge connector is supplied to the XMC P15 VPWR pins. In External Power options (80363-1-L0A, 80363-3-L0A and 80363-5-L0A) VPWR (typically +12V) is supplied via the Auxiliary Power connector J9 to the XMC P15 VPWR pins. External power options must be used when more power than is available from the hosts' PCIe slot is needed for the XMC module operation or other than +12V VPWR is desired.

In standard Adapter options +3.3V Power to the XMC module is generated on the Adapter board from VPWR using the high efficiency low EMI DC-DC converter which provides up to 6A of current to the XMC. Maximum available current on the VPWR (+12V) rail is dependent on the host system or the external power supply, whichever is used, but should never exceed 10A. +3.3V power rail tracks VPWR on the power-up/power-down, so the voltage on +3.3V rail never exceeds the voltage on the VPWR rail; this eliminates a possible latch-up condition on the XMC module.

In standard options the XMC +12V Auxiliary power input is connected to the XMC VPWR rail. The XMC -12V Auxiliary rail is supported via the external J2 connector with an external power supply.

Note that it is possible to use voltage other than +12V (i.e. +5V) for the XMC VPWR through the J9 Auxiliary Power connector. In this case JP1 jumper must be removed to avoid shorting the host's +12V power to the external +5V power supply. Also an additional Adapter board modification (removing R60 resistor) will be required if the XMC Auxiliary +12V voltage is needed; in this case the +12V voltage must be supplied externally via the J2 connector. Contact Innovative for more information if this option is required.

3.3VAUX from the PCIe edge connector is directly routed to the XMC module. Current consumption from the 3.3VAUX rail on the XMC module should not exceed the maximum current allowed by the host system (typically <0.375A).

The Adapter board incorporates a VPWR voltage monitor which turns on the XMC power only when the input voltage is within the range allowed for the VPWR (+4.3V to +14.7V). Otherwise the XMC power will be shut down (both VPWR and +3.3V rails). The monitor also controls the Adapter's power-up and power-down sequences ensuring safe XMC module operation.

Two XMC Current monitors let the user to measure the current consumption of the XMC module on the VPWR and +3.3V rails. Current Monitors generate voltage outputs proportional to the measured current. Current monitor voltage outputs are accessible from the Adapter board power Test Header J11. Accuracy of the current monitors is not guaranteed by Innovative, however by design it should be no worse than +/-10% of the measured current in the range from 0.5A to 10A. The external voltmeter used to measure voltage outputs of the current monitors must have high input resistance (at least 1 MOhm is recommended) and accuracy no worse than +/- 1% in the range from 0.1V to 3.0V. Both current monitors are capable of measuring up to 12A of current. The current is calculated according to the formula:

$$I_{out} (A) = 5 \times V_{out} (V)$$

Where: I_{out} - the XMC module current on VPWR or +3.3V rails in Amps;

PCIe-XMC x8 Adapter

Vout – voltage measured at the current monitor’s output in Volts.

USB JTAG Programmer

The on-board USB JTAG Programmer circuit allows the user to program/access FPGA or other devices with JTAG interface on the XMC module via the P15 connector without using any external programming hardware. The USB JTAG Programmer connects to the host’s (or other PC) USB 2.0 type port via the micro USB type connector accessible from the DIO board bracket. The host must have the appropriate JTAG programming software (such as Xilinx Impact or Vivado Lab tools) installed for the programmer operation. Xilinx tools can be obtained free of charge from the Xilinx web site:

<https://www.xilinx.com/support/download.html>

In addition, the Adept 2 software package from Digilent is required; it can be downloaded from the Digilent web site free of charge:

<http://store.digilentinc.com/digilent-adept-2-download-only/>

The JTAG signals to XMC module have 3.3V LVTTTL logic levels as specified in the VITA 42.3 standard. Note that the JTAG selector switch SW2 must be in position 2 (Internal JTAG enabled) when the internal USB JTAG programmer is used.

If for some reason it is preferable to use an external JTAG programmer (such as Xilinx Platform Cable USB II or similar), it can be connected to the 14-pin JTAG header J13; it has a Xilinx compatible pinout. In this case the JTAG selector switch SW2 must be in position 1 (External JTAG enabled).

Some XMC modules do not support JTAG programming via the P15 connector. However they usually have some kind of a JTAG header for programming. To allow operation with these XMC modules, the Adapter board provides a 14-pin JTAG output header J17 with Xilinx compatible pinout. This header can be connected with an appropriate cable to the XMC module’s JTAG header. For example, all Innovative X6 series XMC modules have 14-pin Xilinx compatible headers on the side of the module. A 14-pin flat ribbon cable can be used to facilitate JTAG programming with these modules.

PCIe-XMC x8 Adapter

Adapter Board Connectors

J1 – SMBus Debug Header

J1 can be used for monitoring and debugging SMBus operation in the host system.

Pin	Signal	Note
1	GND	Ground
2	SMCLK	SMBus Clock
3	SMDAT	SMBus Data

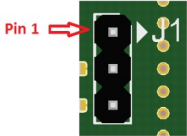

J1 Header Pinout

Connector type: 3M 951103-8622-AR

Mating connector: N/A

J2 – XMC Auxiliary +12V and -12V Connector

J2 provides external +12V and -12V Auxiliary power to the XMC module.

Pin	Power	Note
1	+12V	Auxiliary XMC +12V
2	-12V	Auxiliary XMC -12V
3	GND	Ground

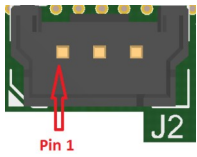

J2 Connector Pinout (top view)

Caution: Incorrect connections may cause board and/or XMC module damage!

Note: In all standard Adapter configurations pin 1 of the J2 connector is internally connected to the VPWR rail on the Adapter board via the R60 resistor. To use the external Auxiliary +12V power supply with the J2 connector the R60 resistor must be removed.

Connector type: Molex 35362-0350

Mating connector: Molex 35507-0300 or equivalent

PCIe-XMC x8 Adapter

J3, J4, J5, J6, J7 – SSMC Timing Signal Connectors

The Adapter has five SSMC type RF jacks that connect to XMC connector P16 as shown in the following table. On Innovative XMC modules, these are connections for the clock, trigger and PPS inputs to the modules.

SSMC Jack	Signal	P16 Connection	Innovative XMC Module Function
J3	CLOCK_P	A9	External Clock Input (P)
J4	CLOCK_N	B9	External Clock Input (N)
J5	TRIGGER_P	A19	External Trigger Input (P)
J6	TRIGGER_N	B19	External Trigger Input (N)
J7	1 PPS	D19	1 PPS (Pulse Per Second) Signal Input

Connectors type: APPLIED ENGINEERING PRODUCTS 7010-1511-000
Mating cables: Standard SSMC cable assemblies

Notes:

1. Depending on the XMC module used, the clock and trigger signals can be differential or single ended. Consult the XMC module's documentation for detailed information.
2. In all standard Adapter options connections from the SSMC jacks to P15 pins are DC-coupled and no load is present on the Adapter board itself. It is however possible to add load resistors, AC-coupling capacitors or resistive dividers on these inputs as shown in the J16 connector section. Contact Innovative if one of these options is required.

J8 – High-Speed Serial Link Connector

J8 provides eight high speed serial lanes from/to the XMC module supporting Gigabit serial ports for module to module communications or expansion. The serial lanes connect directly to the J8 connector. On Innovative XMC modules these lanes are typically connected to the FPGA Multi-Gigabit (MGT) type transmitters. Two industry standard MiniSAS HD type cables must be used to connect to the optional Satellite board. These cables (P/N 67238) are supplied with Satellite board by Innovative and can also be ordered separately. It is also possible to create a board to board direct high-speed connection without the optional Satellite board.

On the Satellite board the high-speed serial lanes connect directly to the two QSFP type connectors which are accessible from the board's bracket. Innovative XMC modules support Xilinx developed high-speed Aurora interface; when using all eight receiver/transceiver pairs communication speeds up to 3 Gbps are achievable.

The Satellite board has provisions to support full QSFP mode of operation, including QSFP module management features. Contact Innovative for further information if the full featured QSFP mode of operation is desired.

PCIe-XMC x8 Adapter

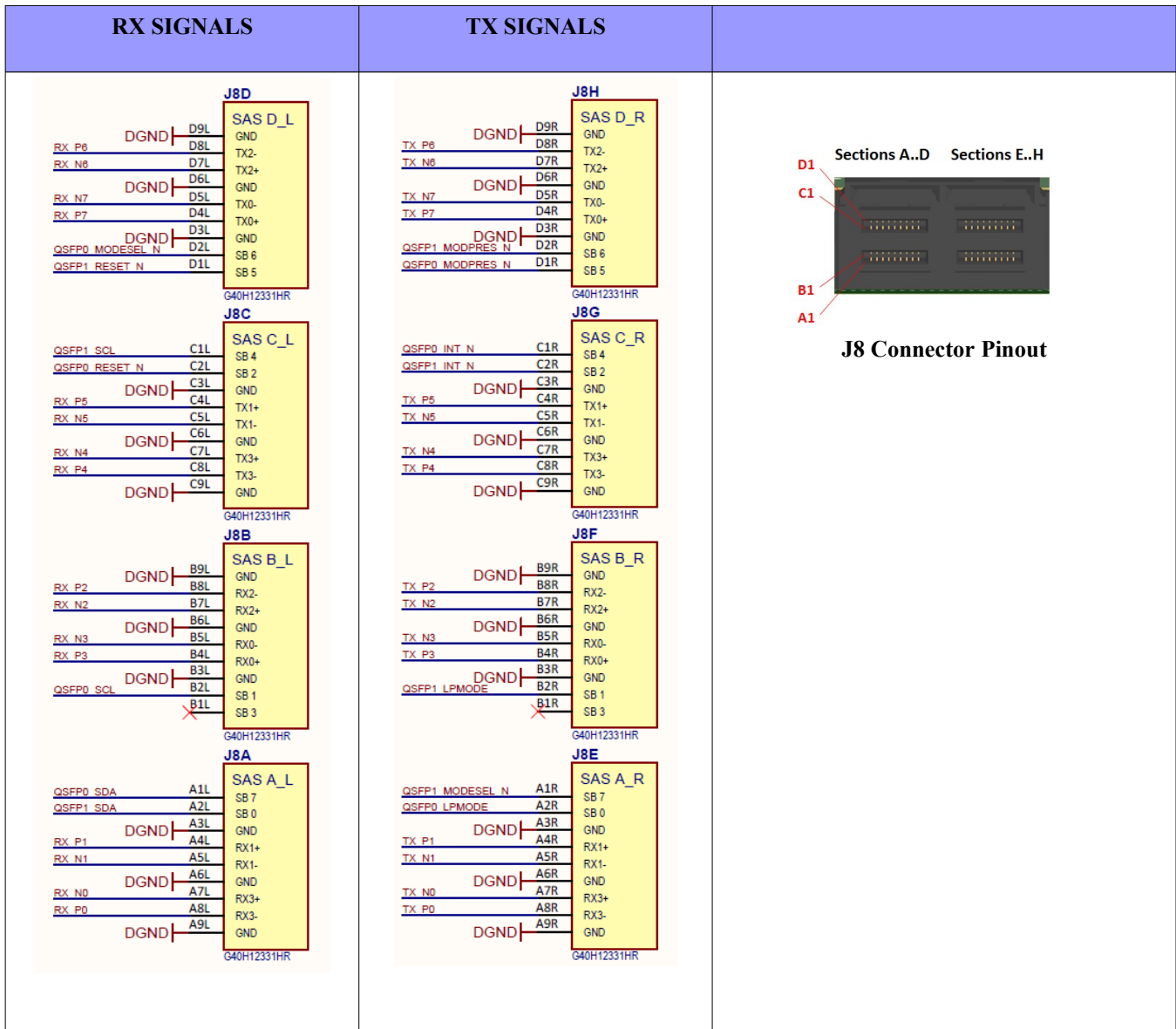

Notes:

1. The J8 connector pinout on the Adapter does not match the standard MiniSAS HD SB signal assignment.
2. See the Adapter board connector J16 and the Satellite board connector J1 sections for additional information.
3. See the Board Connections section for cabling and board to board connection information.

Connector type:

Amphenol G40H12331HR

Mating cable (2 required):

3M 8US4-CB119-00-0.50 (Innovative P/N 67238); Basic High-Speed Link Mode
 3M 8US4-AA119-00-0.50 (Innovative P/N 67234); Full QSFP support

PCIe-XMC x8 Adapter

J9 – Auxiliary Power Connector

J9 provides VPWR (normally +12V) to the XMC module.

DO NOT HOT PLUG THE CONNECTOR! Damage may occur.

Pin	Power	
1, 3, 5	VPWR	 <p>J9 Connector Pinout (view from the mating side)</p>
2, 4, 6	Ground	

Caution: Incorrect connections may cause Adapter board and/or XMC module damage!

Connector type: TE CONNECTIVITY 1586041-6
Mating connector: TE CONNECTIVITY 1586019-6 or equivalent

J10 and J12 – Fan Power Headers

J10 and J12 provide power for the Adapter cooling fans. These headers are reserved for Innovative use; the information below is provided for reference only.

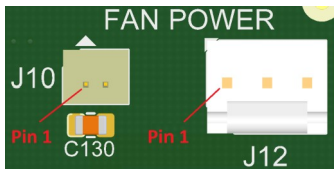
J11 Pins	J12 Pins	Power	
1	1	VPWR (+12V)	 <p>J10 and J12 Header Pinout</p>
2	2	Ground	
N/A	3	Not connected	

J10 Connector type: Hirose DF13-2P-1.25DSA(20)
J10 Mating connector: Hirose DF13-2S-1.25C (housing); Hirose DF13-2630SCFA (crimp; 2 required)

J12 Connector type: TE Connectivity 640456-3
J12 Mating connector: TE Connectivity 3-640440-3 or equivalent

PCIe-XMC x8 Adapter

J11 – Voltage and Current Test Header

J11 allows user to measure all main power voltages on the Adapter board as well as the XMC module current monitor outputs. The 1 KOhm resistors placed in series with the measured signals protect the on-board voltages from accidental shorts when performing the measurements.

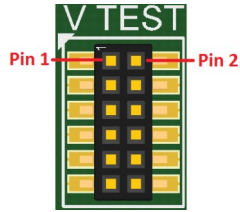
Pin	Signal	Note	
1	PCIE_3P3V	+3.3V from the PCIe Slot Finger Connector	 <p>J11 Header Pinout</p>
2	PCIE_12P0V	+12V from the PCIe Slot Finger Connector	
3	3P3V	Adapter's +3.3V Rail. In all standard options is generated on-board, so it is not the same as PCIE_3P3V	
4	VPWR_IN	VPWR input to the board. It is the same as PCIE_12P0V for Internal Power configuration. For External Power configuration it is the voltage applied from the J9 Auxiliary connector	
5	XMC_3P3V	+3.3V at the XMC P15 Connector	
6	VPWR	VPWR at the VPWR Switch output	
7	XMC_3P3VAUX	3.3V AUX at the XMC P15 Connector	
8	XMC_VPWR	VPWR at the XMC P15 Connector	
9	XMC_N12P0V	Auxiliary -12V at the XMC P15 connector. Same as the external -12V from the J2 connector (only when present)	
10	XMC_P12P0V	Auxiliary +12V at the XMC P15 connector. In standard Adapter options same as VPWR	
11	XMC_3P3V_IMON	Voltage output of the XMC +3.3V rail current monitor*	
12	XMC_VPWR_IMON	Voltage output of the XMC VPWR rail current monitor*	

Note: See the Power to the XMC Module section for additional information on the Current Monitors operation.

Connector type: FCI 20021321-00012C4LF

Mating connector: N/A

PCIe-XMC x8 Adapter

J13 – XMC JTAG Header

J13 is a 14-pin JTAG header which is used with external JTAG programmer device such as the Xilinx Platform Cable USB II to monitor or program devices included in the JTAG chain on the XMC module. Note that when an external programmer is used, the JTAG programmer selector switch SW2 must be in position 1 (External JTAG enabled). The J13 header pinout is compatible with the Xilinx programmer pinout.

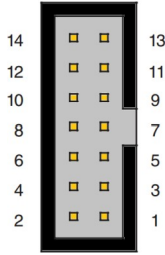
J13 Pins	Signal	Note	
2	PCIE_3P3V	+3.3V JTAG Reference voltage	 <p>J13 Header Pinout</p>
4	TMS	JTAG TMS signal	
6	TCK	JTAG TCK signal	
8	TDO	JTAG TDO signal	
10	TDI	JTAG TDI signal	
14	TRST#	JTAG TRST# signal*	
1, 3, 5, 7, 9, 11, 13	GND	Ground	

Note: TRST# signal is typically not used when programming Xilinx FPGA-s.

Connector type: Molex 87831-1420
Mating connector: Molex 87568-1444 or equivalent

PCIe-XMC x8 Adapter

J14 – DIO Board Connector

J14 connects the main Adapter board to the DIO board; it is not user accessible. The information below is provided for reference only.

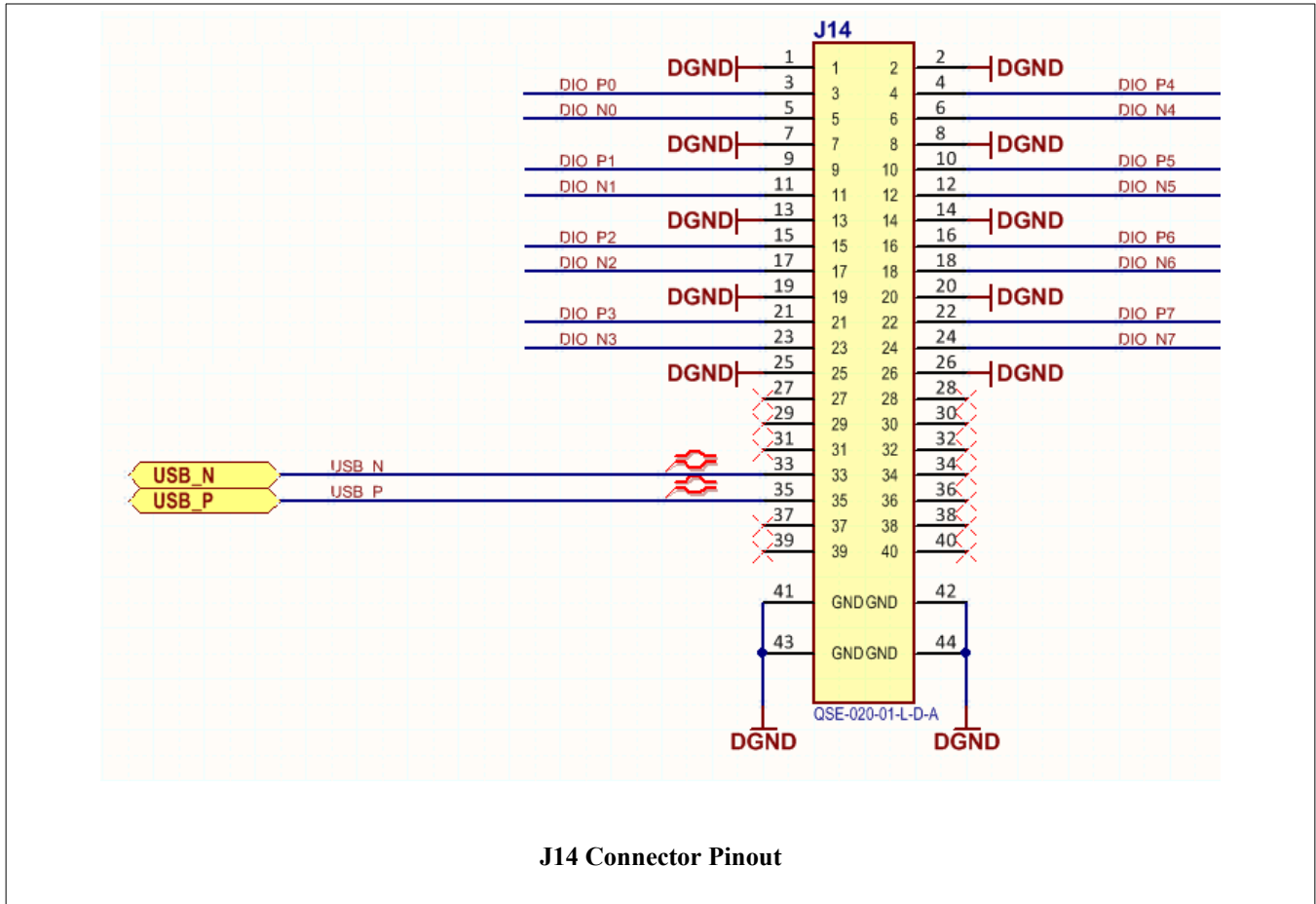

Note: See the Board Connections section for the DIO signal connection details in the system.

PCIe-XMC x8 Adapter

J15 – XMC Primary Connector

J15 connects the PCIe backplane and power signals to the XMC module P15 connector. The J15 pinout is VITA 42.3 standard compatible.

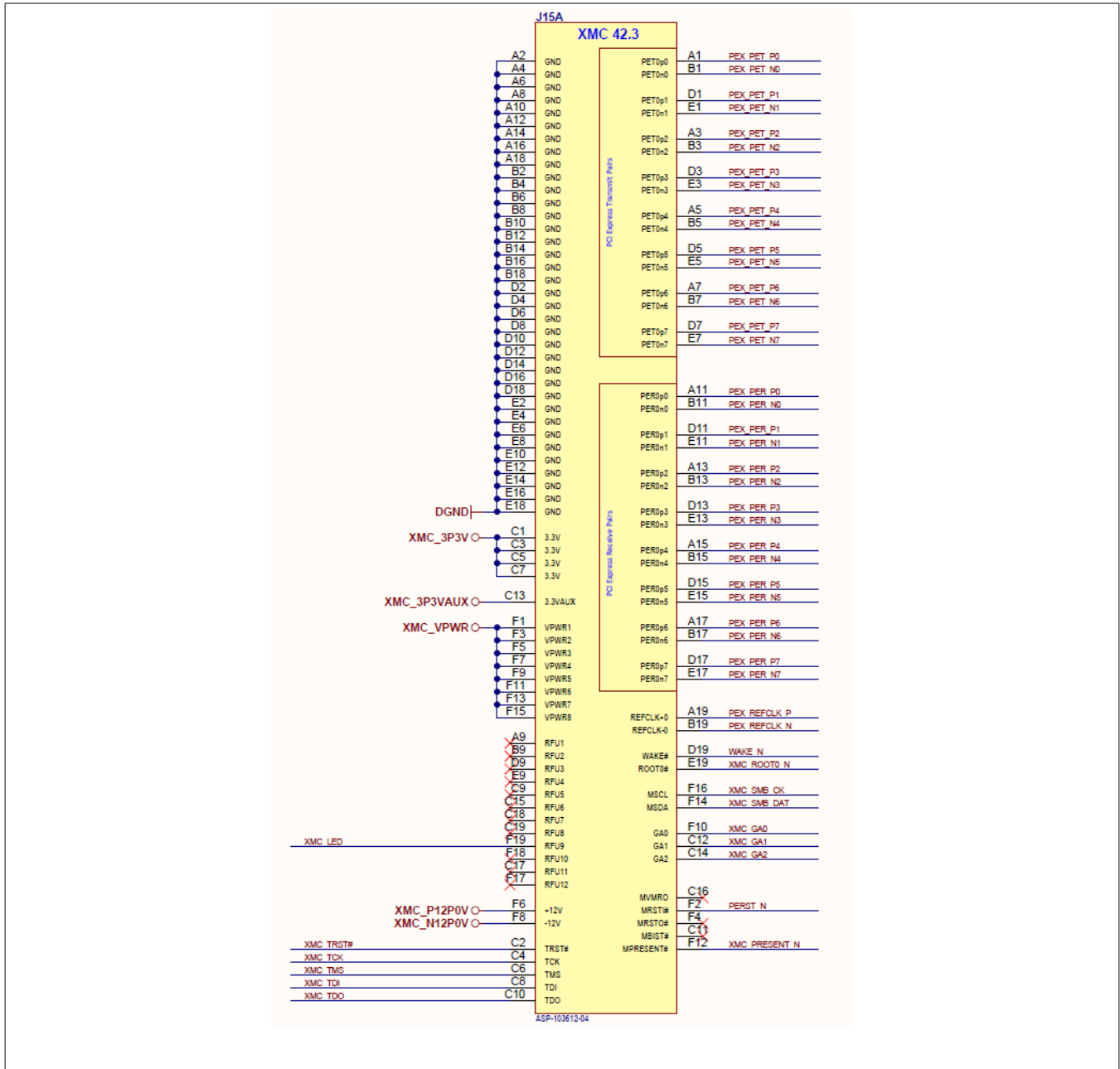

Connector type: Samtec ASP-103612-04
 Mating connector: Samtec ASP-103614-04

PCIe-XMC x8 Adapter

J16 – XMC Secondary Connector

J16 connects to the XMC module P16 connector. It is used to provide user access to the XMC module's I/O signals.

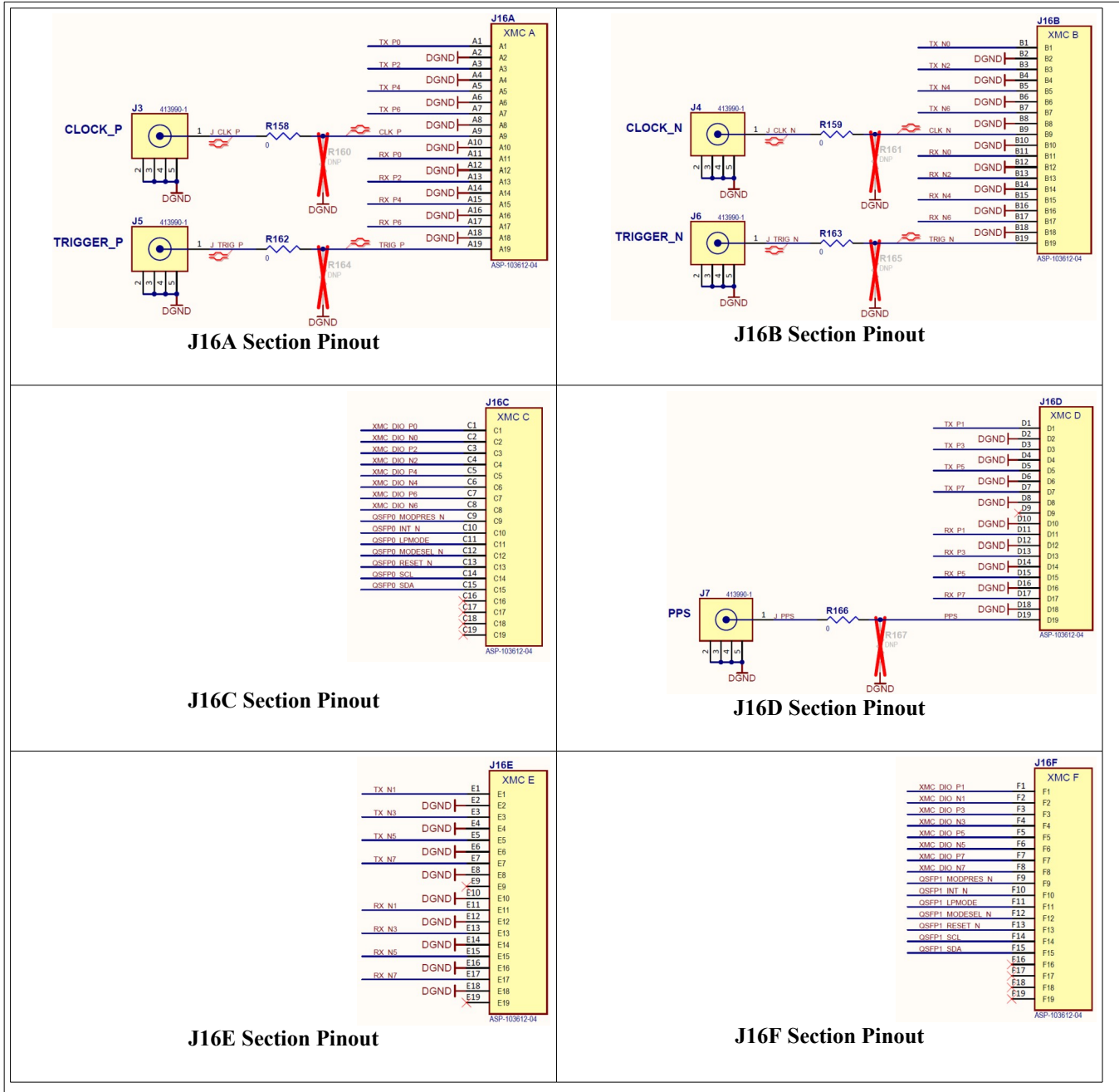

Connector type: Samtec ASP-103612-04

Mating connector: Samtec ASP-103614-04

PCIe-XMC x8 Adapter

J17 – XMC JTAG Header

J17 is a 14-pin JTAG output header with Xilinx compatible pinout. It can be used with XMC modules which do not support JTAG programming via the P15 connector, but have some kind of a JTAG header for programming. This header can be connected with an appropriate cable to the XMC module’s JTAG header. For example, all Innovative X6 series XMC modules have 14-pin Xilinx compatible headers on the side of the module. A 14-pin flat ribbon cable can be used to facilitate JTAG programming with these modules. Either Internal or External JTAG programming mode can be used.

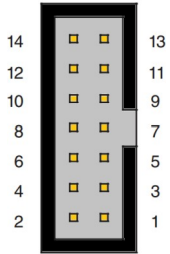
J13 Pins	Signal	Note	
2	JTAG_VREF	JTAG Reference voltage	 <p style="text-align: center;">J17 Header Pinout</p>
4	TMS	JTAG TMS signal	
6	TCK	JTAG TCK signal	
8	TDO	JTAG TDO signal	
10	TDI	JTAG TDI signal	
14	TRST#	JTAG TRST# signal*	
1, 3, 5, 7, 9, 11, 13	GND	Ground	

Note: TRST# signal is typically not used when programming Xilinx FPGA-s.

Connector type: Molex 87831-1420
Mating connector: Molex 87568-1444 or equivalent

PCIe-XMC x8 Adapter

SW1 – XMC Geographic Address Quad DIP Switch

Quad DIP Switch SW1 used for setting the geographic address of the XMC module.

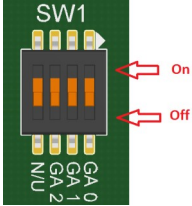
Address	GA 0	GA 1	GA 2	
0	On (0)	On (0)	On (0)	 <p>SW1 Geographic Address Switch On/Off positions</p>
1	Off (1)	On (0)	On (0)	
2	On (0)	Off (1)	On (0)	
3	Off (1)	Off (1)	On (0)	
4	On (0)	On (0)	Off (1)	
5	Off (1)	On (0)	Off (1)	
6	On (0)	Off (1)	Off (1)	
7	Off (1)	Off (1)	Off (1)	

Note:

1. The Geographic Address switch “Off” position corresponds to the logic “High” level on the GA pins and the switch “On” position corresponds to the logic “Low” level on the GA pins.
2. Only 3 out of 4 DIP switches in the package are used. The fourth unused switch marked as N/U on the board.

SW2 – JTAG Programmer Selector Switch

DIP Switch SW2 used for selecting JTAG programming mode – Internal (using the internal USB JTAG circuit) or External (using an external JTAG programmer).

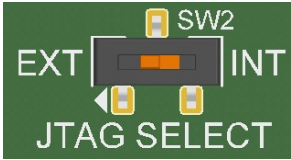
Position	Function	
1	External JTAG Programmer selected	 <p>SW2 - JTAG Programmer Selector Switch</p>
2	Internal JTAG Programmer selected	

PCIe-XMC x8 Adapter

LED Indicators

Four LED indicators (LED1 to LED4) are located on the edge of the Adapter board and used as power status and the XMC module presence indicators.

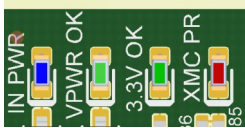
FUNCTION	LED #	COLOR	NOTE	
INPUT POWER PRESENT	1	Blue	Adapter Input Power Is ON	 <p style="text-align: center;">Adapter Board LED Indicators</p>
VPWR OK	2	Green	VPWR to XMC is ON	
+3.3V OK	3	Green	+3.3V to XMC is ON	
XMC PRESENT	4	Red	XMC Module is present	

PCIe-XMC x8 Adapter

Satellite Board Connectors

J1 – High-Speed Serial Link Connector

J1 connects to the J8 connector on the Adapter board with two industry standard MiniSAS HD type cables; these cables are included with the Satellite board order.

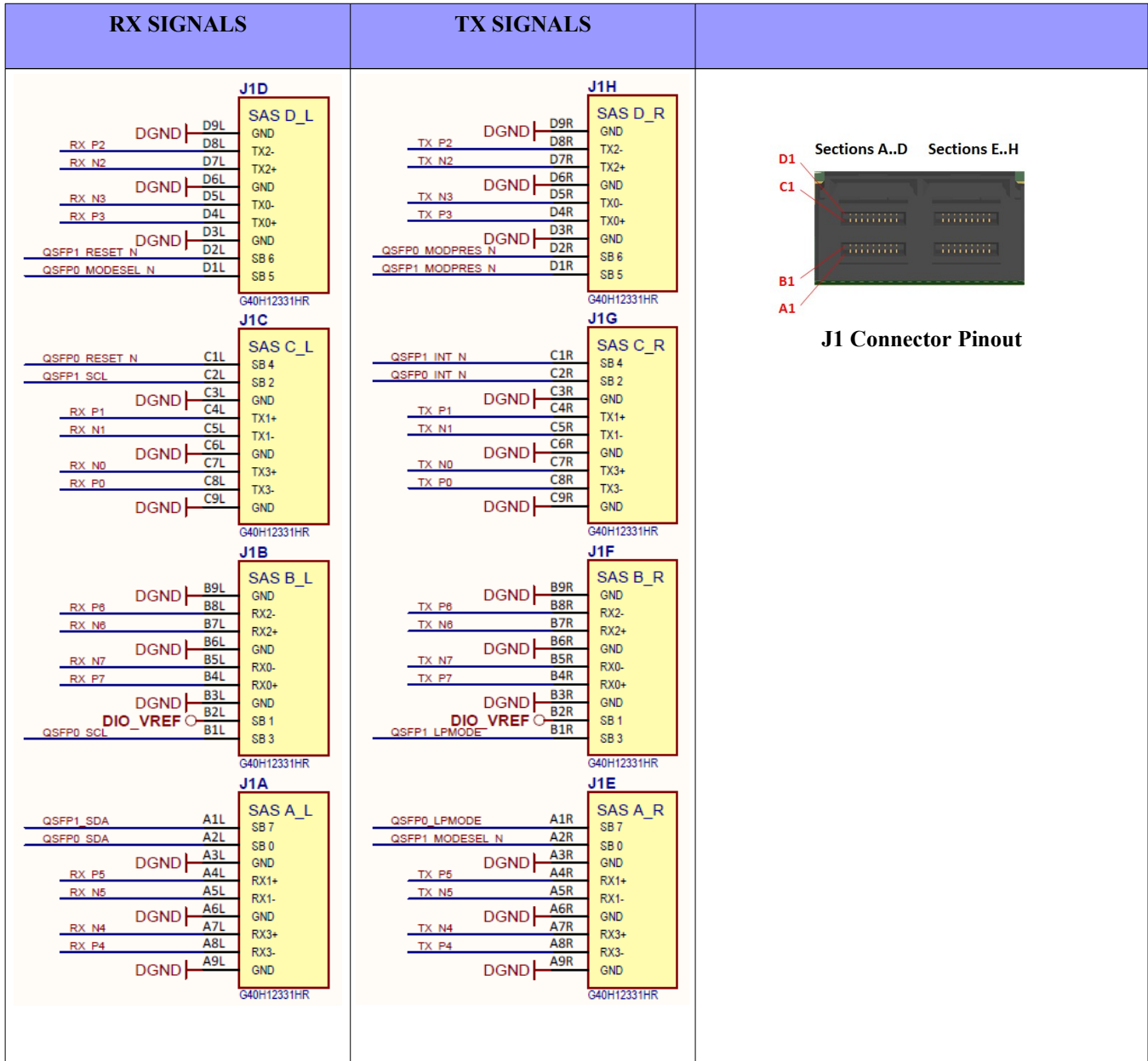

PCIe-XMC x8 Adapter

Notes:

1. The J1 connector pinout on the Satellite board does not match the standard MiniSAS HD SB signal assignment.
2. See the Adapter board connector J8 and connector J16 sections for additional information.
3. See the Board Connections section for cabling and board to board connection information.

Connector type: Amphenol G40H12331HR
Mating cable (2 required): 3M 8US4-CB119-00-0.50 (Innovative P/N 67238); Basic High-Speed Link Mode
 3M 8US4-AA119-00-0.50 (Innovative P/N 67234); Full QSFP Support Mode

J3 and J2 – QSFP 0 and QSFP 1 External Connectors

J3 and J2 are the QSFP 0 and QSFP 1 ports providing external access to the high-speed serial link signals.

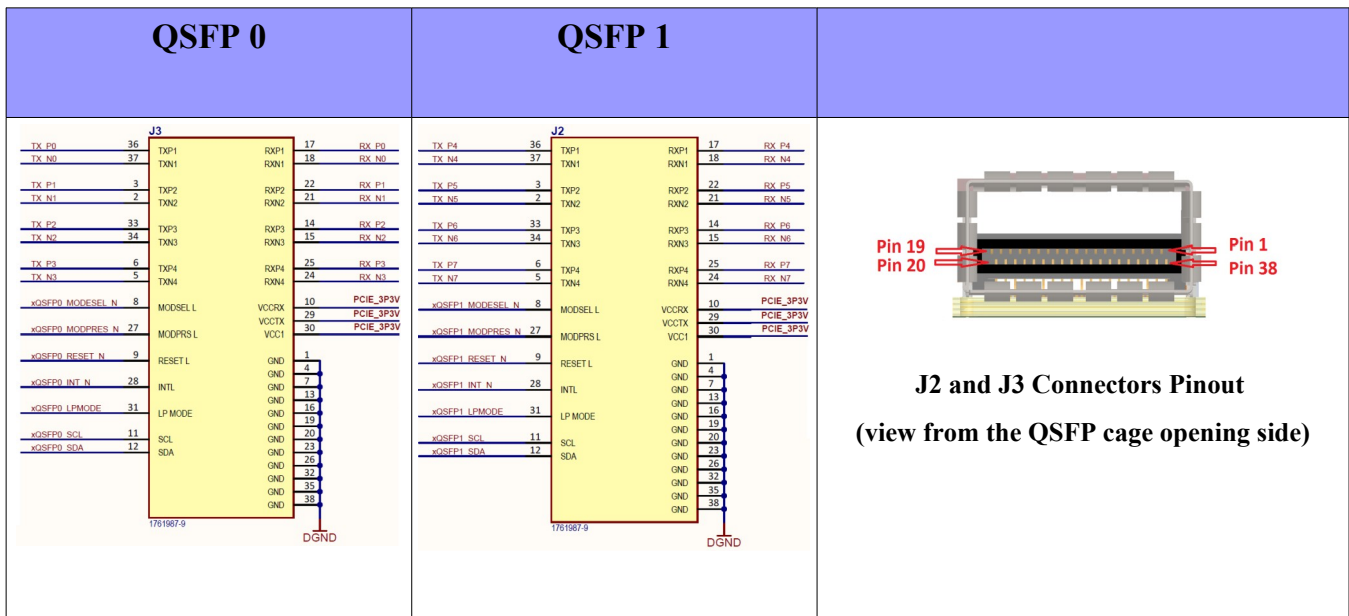

Notes:

1. Both copper and optical QSFP/QSFP+ links are supported.
2. QSFP control signals have +3.3V LVTTTL levels. Net labels with the letter “x” prefix mark the logic control signals converted to +3.3V levels. The Satellite board can work with +2.5V powered FPGA Banks (80369-0-L0 option) or +1.8V powered FPGA Banks (80369-1-L0 option). 80369-2-L0 option provides only the high-speed link and does not support QSFP control signals – they are simply disconnected and the FPGA bank voltage is irrelevant in this case.
3. See the Board Connections section for cabling and board to board connection information.

PCIe-XMC x8 Adapter

Connector type: TE CONNECTIVITY 1761987-9
Mating cable (2 required): Industry standard QSFP or QSFP+ cables; both optical and copper types can be used

DIO Board Connectors

J1 – DIO Connector

J1 provides user with access to 8 differential/16 single ended DIO signal pairs from the XMC module. It is located on the DIO board bracket. Innovative offers a special breakout board which provides convenient access to DIO signals via 16 SMA type connectors and a choice of the specially designed high-speed Twinax cables.

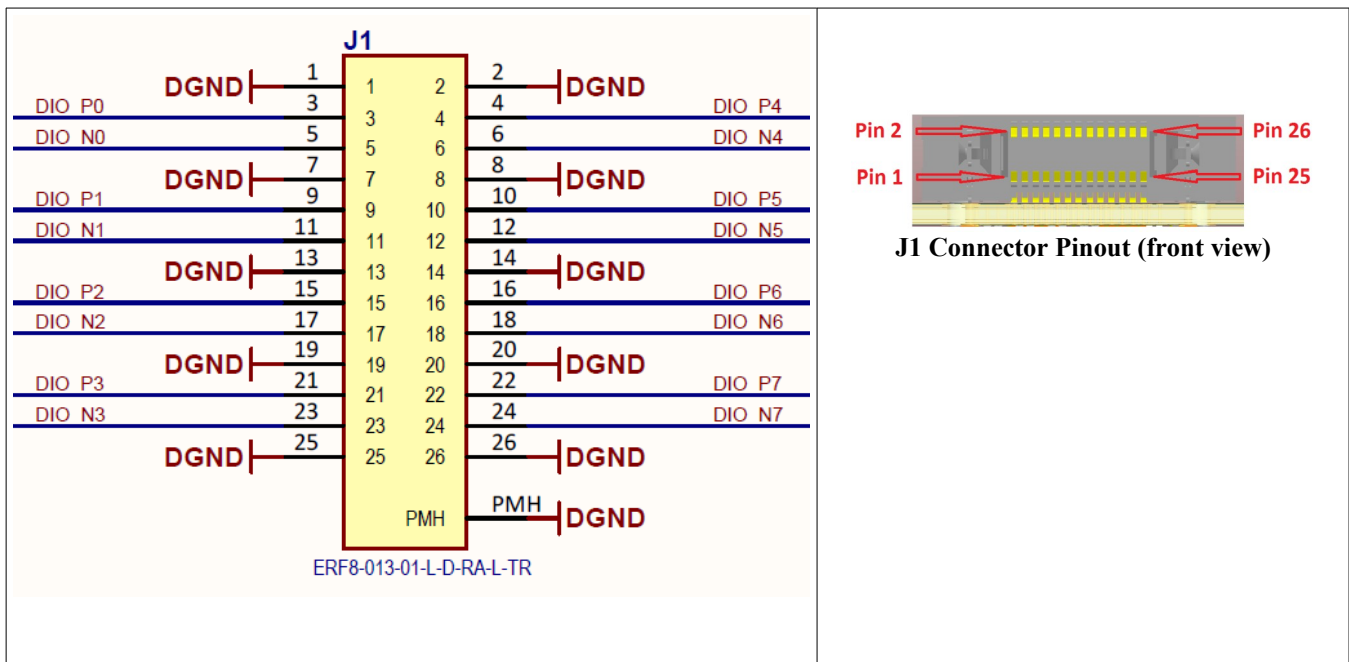

Notes:

1. DIO traces are routed as differential pairs with 100 Ohm characteristic impedance. Small value resistors (5 Ohms) are placed in series on these signals for protection.
2. The maximum speed achievable for DIO signals depends on the XMC board's FPGA DIO drivers, the mode of operation (single ended or differential), cabling and the user DIO circuitry.

Connector type: Samtec ERF8-013-01-L-D-RA-L-TR
Mating cable/breakout board: Please see the ordering section for available cabling and breakout board options.

PCIe-XMC x8 Adapter

J2 – Micro USB Connector

J2 is a micro USB type B jack. It can be accessed from the DIO board bracket and used by the Adapter's USB JTAG programmer circuitry for the JTAG programming operations. A standard USB 2.0 type A to micro USB type B cable can be used to connect to the host USB 2.0 port. Since the Adapter is a slave USB device and no external power is required, pin 1 of the connector has no internal connections.

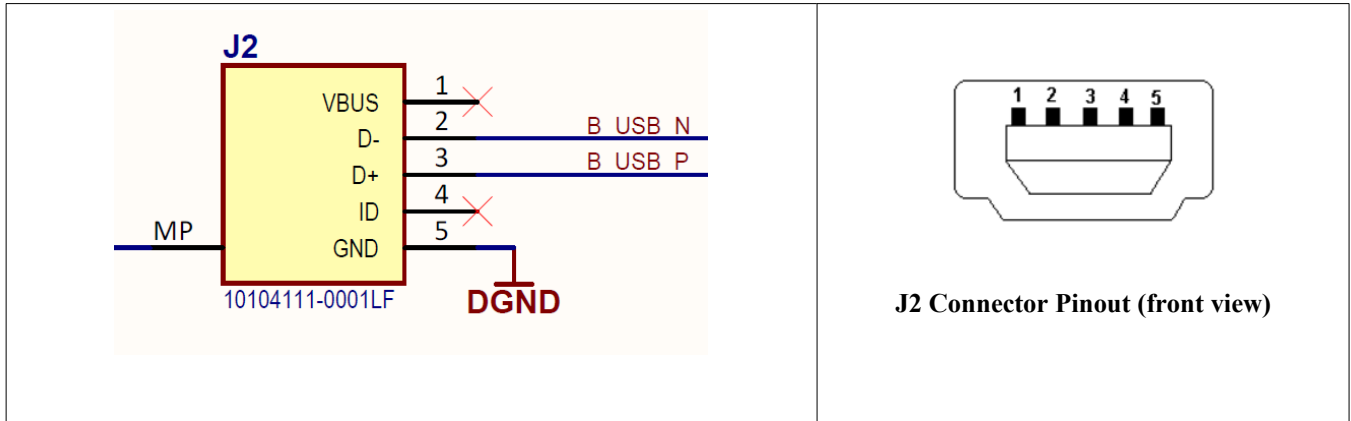

Connector type: FCI 10104111-0001LF
Mating cable: USB 2.0 type A to micro USB type B industry standard cables

PCIe-XMC x8 Adapter

P1 – Adapter Board Connector

P1 connects the DIO board to the main Adapter board; it is not user accessible. The information below is provided for reference only.

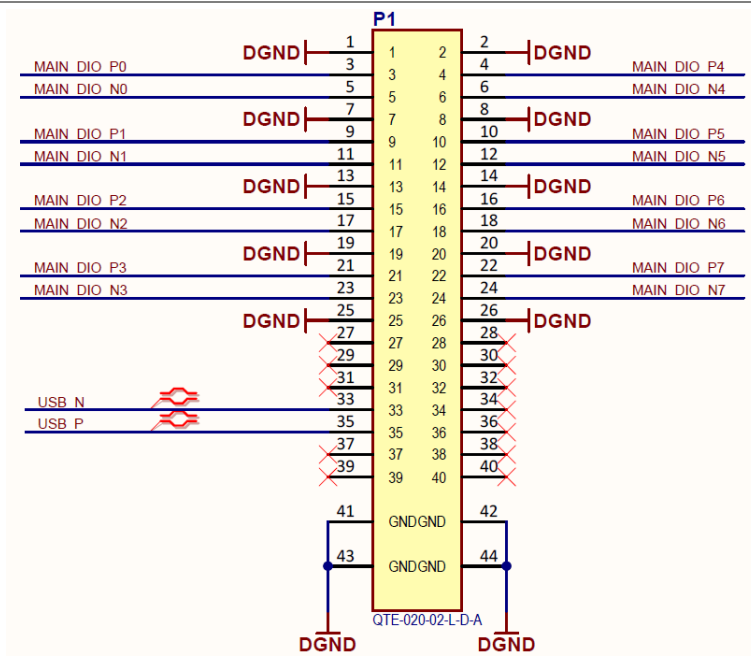

P1 Connector Pinout

Note: See the Board Connections section for the DIO signal connection details in the system.

PCIe-XMC x8 Adapter

Board Connections

High Speed Serial Pairs

XMC PCIe Adapter Board			XMC PCIe Adapter Satellite Board		
High Speed Serial Pair	J16 Pins (P/N)	J8 Pins (P/N)	J1 Pins (P/N)	J3 (QSFP 0) Pins (P/N)	J2 (QSFP 1) Pins (P/N)
TXP0/N0	A1/B1	A8R/A7R	C8R/C7R	36/37	N/A
TXP1/N1	D1/E1	A4R/A5R	C4R/C5R	3/2	N/A
TXP2/N2	A3/B3	B8R/B7R	D8R/D7R	33/34	N/A
TXP3/N3	D3/E3	B4R/B5R	D4R/D5R	6/5	N/A
TXP4/N4	A5/B5	C8R/C7R	A8R/A7R	N/A	36/37
TXP5/N5	D5/E5	C4R/C5R	A4R/A5R	N/A	3/2
TXP6/N6	A7/B7	D8R/D7R	B8R/B7R	N/A	33/34
TXP7/N7	D7/E7	D4R/D5R	B4R/B5R	N/A	6/5
RXP0/N0	A11/B11	A8L/A7L	C8L/C7L	17/18	N/A
RXP1/N1	D11/E11	A4L/A5L	C4L/C5L	22/21	N/A
RXP2/N2	A13/B13	B8L/B7L	D8L/D7L	14/15	N/A
RXP3/N3	D13/E13	B4L/B5L	D4L/D5L	25/24	N/A
RXP4/N4	A15/B15	C8L/C7L	A8L/A7L	N/A	17/18
RXP5/N5	D15/E15	C4L/C5L	A4L/A5L	N/A	22/21
RXP6/N6	A17/B17	D8L/D7L	B8L/B7L	N/A	14/15
RXP7/N7	D17/E17	D4L/D5L	B4L/B5L	N/A	25/24

PCIe-XMC x8 Adapter

QSFP Control Signals

XMC PCIe Adapter Board			XMC PCIe Adapter Satellite Board		
Signal	J16 Pins	J8 Pins	J1 Pins	J3 (QSFP 0) Pins	J2 (QSFP 1) Pins
QSFP1_MODESEL_N	F12	A1R	A2R	N/A	8
QSFP0_LPMODE	C11	A2R	A1R	31	N/A
Reserved	N/A	B1R	B2R	N/A	N/A
QSFP1_LPMODE	F11	B2R	B1R	N/A	31
QSFP0_INT_N	C10	C1R	C2R	28	N/A
QSFP1_INT_N	F10	C2R	C1R	N/A	28
QSFP0_MODPRES_N	C9	D1R	D2R	27	N/A
QSFP1_MODPRES_N	F9	D2R	D1R	N/A	27
QSFP0_SDA	C15	A1L	A2L	12	N/A
QSFP1_SDA	F15	A2L	A1L	N/A	12
Reserved	N/A	B1L	B2L	N/A	N/A
QSFP0_SCL	C14	B2L	B1L	11	N/A
QSFP1_SCL	F14	C1L	C2L	N/A	11
QSFP0_RESET_N	C13	C2L	C1L	9	N/A
QSFP1_RESET_N	F13	D1L	D2L	N/A	9
QSFP0_MODESEL_N	C12	D2L	D1L	8	N/A

Note: The Satellite Board incorporates level shifters for the QSFP control signals and supports connection with +2.5V powered FPGA Banks (80369-0-L0 option) or +1.8V powered FPGA Banks (80369-1-L0 option). On the 80369-2-L0 option QSFP control signals are disconnected.

PCIe-XMC x8 Adapter

Adapter Board to Satellite Board Connections

Basic High-Speed Link Mode

In this mode any Satellite board option can be used since QSFP control signals are not being connected to FPGA on the XMC module.

1. Connect the top section of the J8 connector on the Adapter board to the top section of the J1 connector on the Satellite board with a MiniSAS HD WO/SB cable (Innovative P/N 67238).
2. Connect the bottom section of the J8 connector on the Adapter board to the bottom section of the J1 connector on the Satellite board with another MiniSAS HD WO/SB cable (Innovative P/N 67238).
3. Use industry standard QSFP cables to connect Satellite board to send/receive data to external devices.

Note: In this mode QSFP module control features are not supported.

Full QSFP Support Mode

Make sure that a proper Satellite board option (80369-0-L0 for 2.5V DIO or 80369-1-L0 for 1.8V DIO) is selected to match the used XMC module's DIO signal levels to prevent any potential damage to the XMC module and/or the Satellite board!

1. Connect the top section of the J8 connector on the Adapter board to the top section of the J1 connector on the Satellite board with a MiniSAS HD SB cable (Innovative P/N 67234).
2. Connect the bottom section of the J8 connector on the Adapter board to the bottom section of the J1 connector on the Satellite board with another MiniSAS HD SB cable (Innovative P/N 67234).
3. Use industry standard QSFP cables to connect Satellite board to send/receive data to external devices.

Note: While in this mode all QSFP module control signals are connected, software support for QSFP control features is not included in the standard Innovative XMC module software packages. Contact Innovative for more information if this mode of operation is desired when using Adapter/Satellite board combination with Innovative XMC modules.

PCIe-XMC x8 Adapter

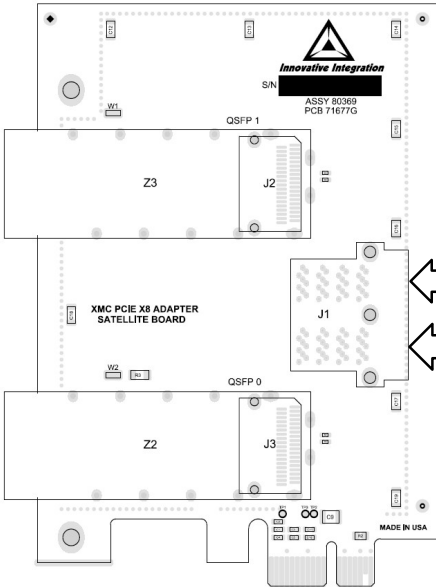
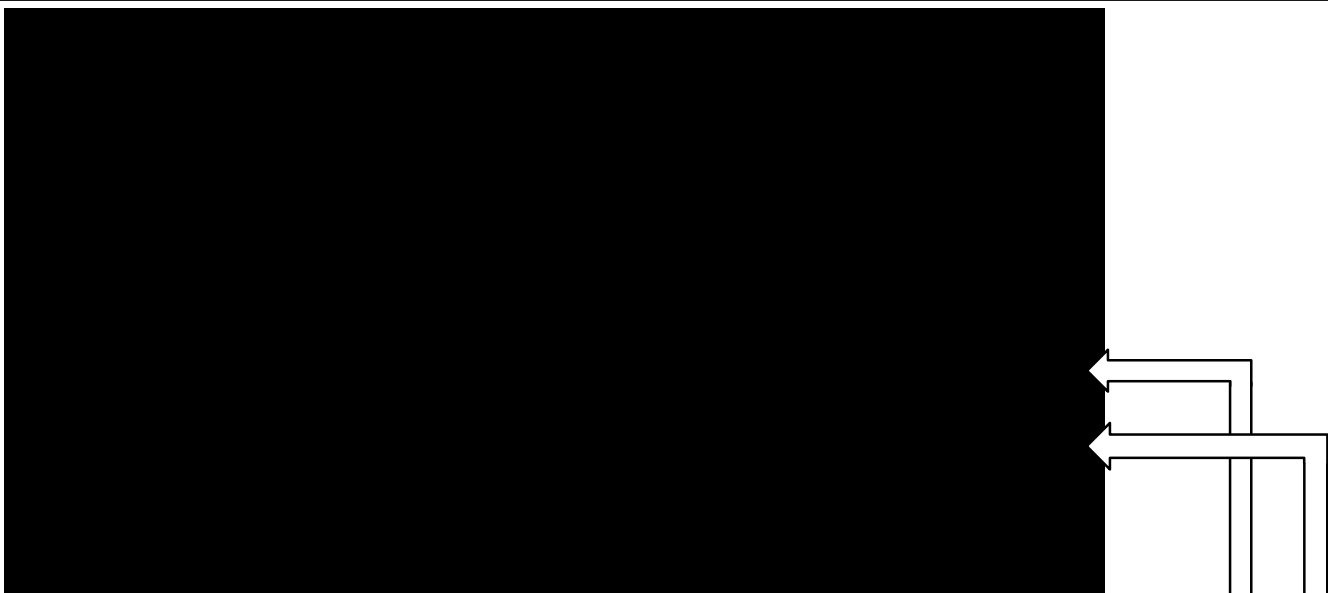

Adapter Board to Satellite Board Connections Diagram

PCIe-XMC x8 Adapter

Connecting Adapter Board to another Adapter Board in the system

1. Connect the top section of the J8 connector on the Adapter board to the bottom section of the J1 connector on the Satellite board with MiniSAS HD WO/SB cable (Innovative P/N 67238).
2. Connect the bottom section of the J8 connector on the Adapter board to the top section of the J1 connector on the Satellite board with MiniSAS HD WO/SB cable (Innovative P/N 67238).

Note: Do not attempt to use MiniSAS HD SB cables (Innovative P/N 67234) when connecting Adapter boards to another Adapter board to avoid signal congestion and potential damage to the connected boards.

PCIe-XMC x8 Adapter

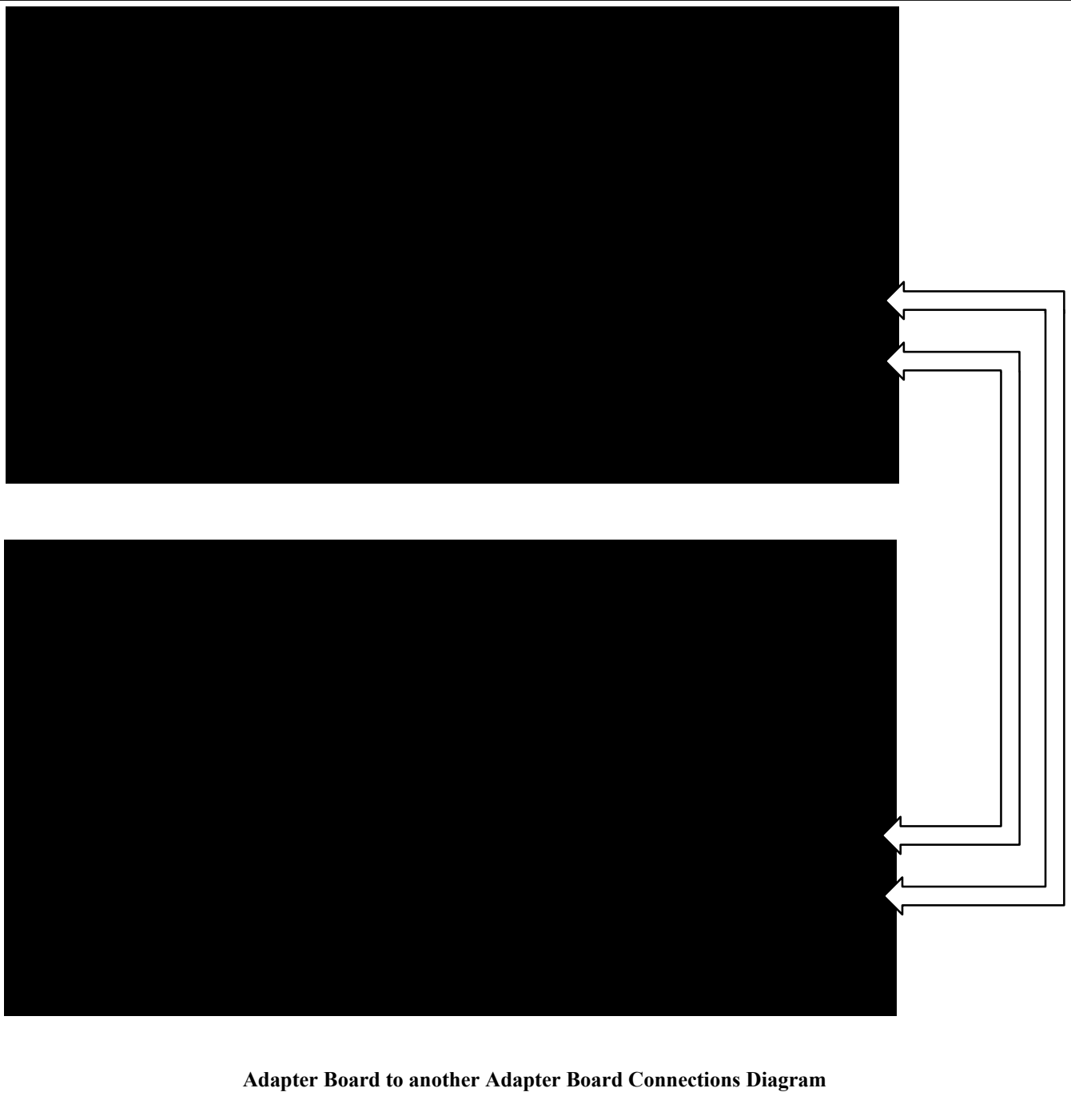

PCIe-XMC x8 Adapter

QSFP Signal Flow

The pictures below illustrate the QSFP signal flow in the system. QSFP module can be either optical or copper type.

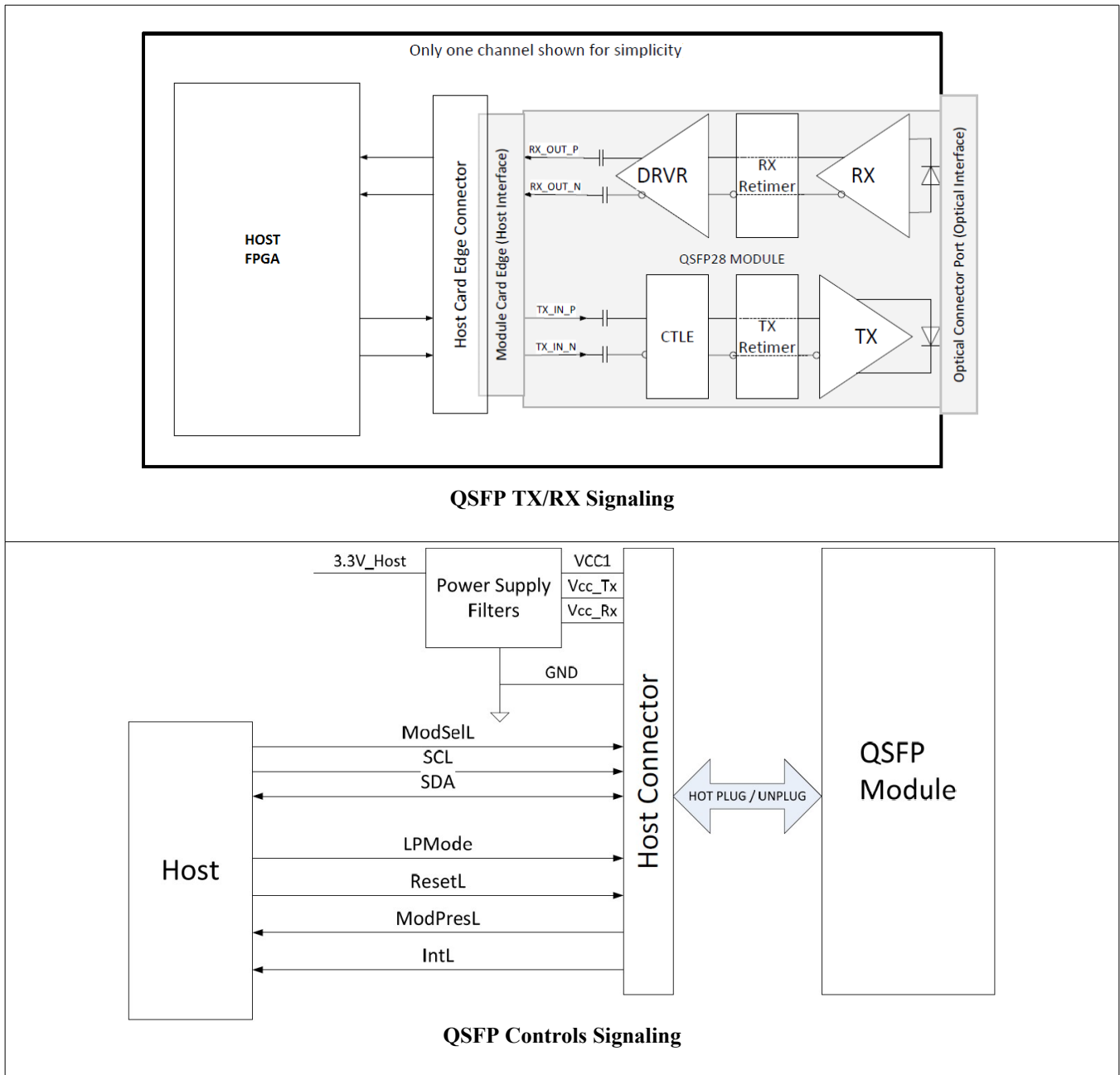

PCIe-XMC x8 Adapter

Board Assembly Graphics

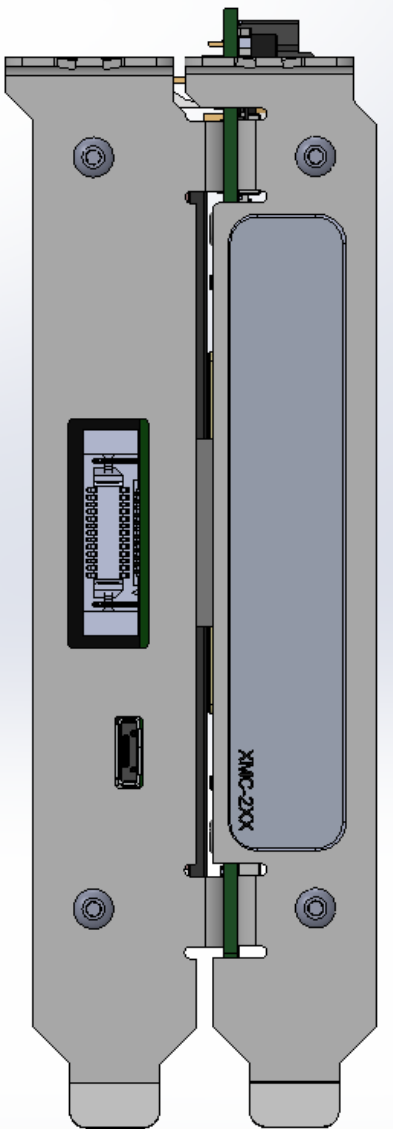

XMC PCIe x8 Adapter Board – view from the bracket side

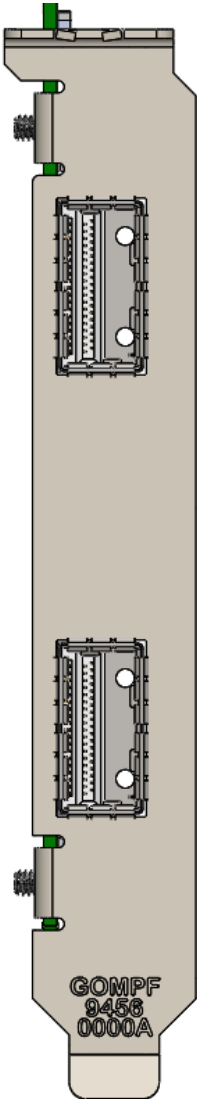

XMC PCIe x8 Adapter Satellite Board – view from the bracket side

PCIe-XMC x8 Adapter

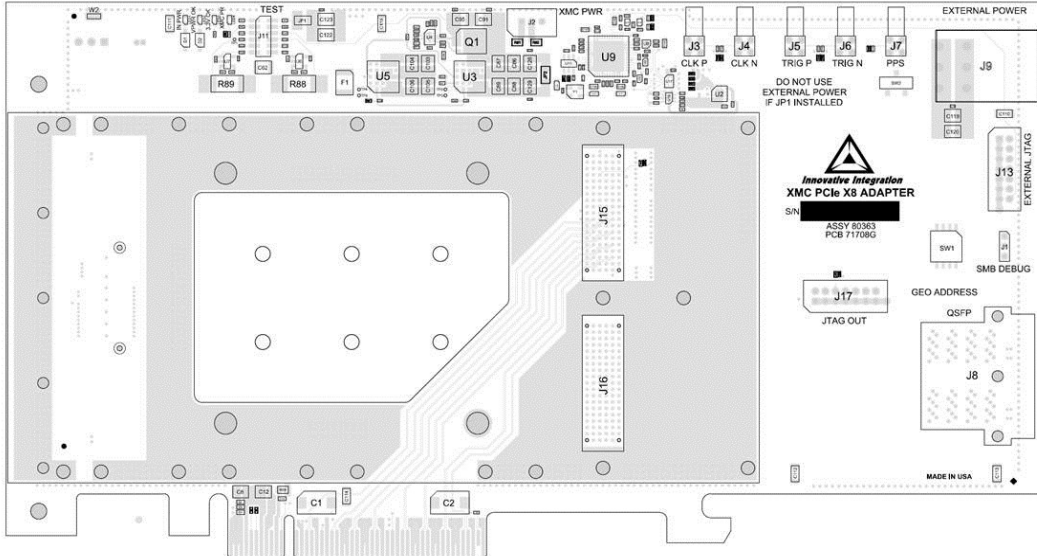

XMC PCIe x8 Adapter Board – Primary Side view

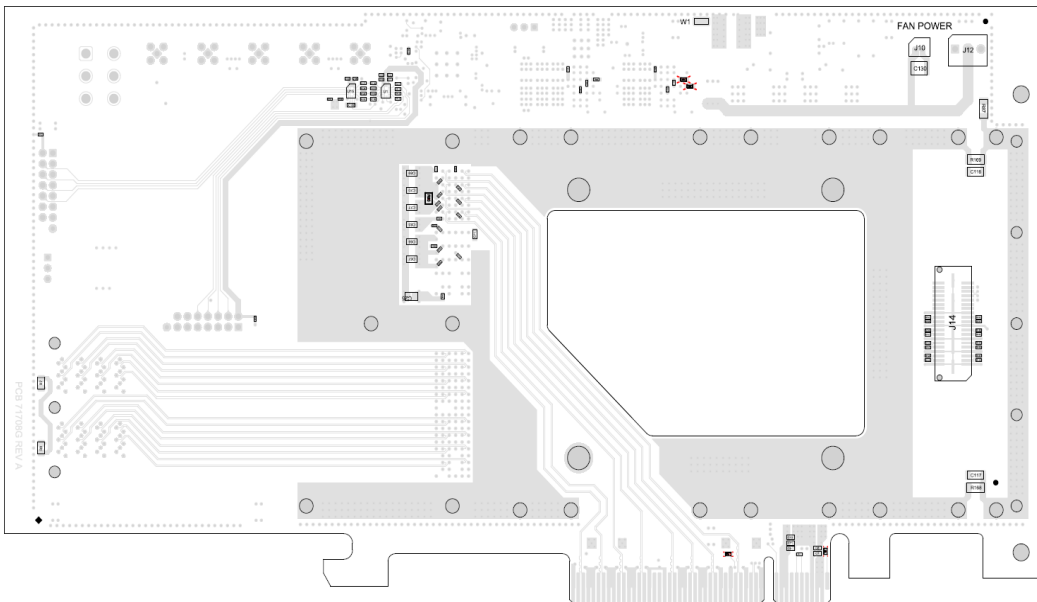

XMC PCIe x8 Adapter Board – Secondary Side view

PCIe-XMC x8 Adapter

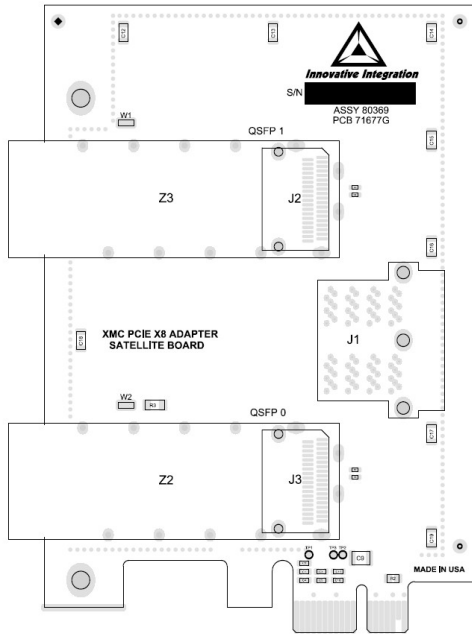

XMC PCIe x8 Adapter Satellite Board – Primary Side view

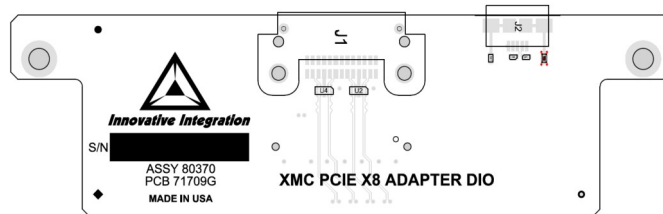

XMC PCIe x8 Adapter DIO Board – Primary Side view

PCIe-XMC x8 Adapter

Cooling the XMC Module

Most XMC modules require special considerations to provide adequate cooling. This Adapter provides a few separate efficient cooling options for XMC modules.

The first variant is a basic single fan and heat frame convection option for low heat dissipating XMC modules (options 80363-2-L0 and 80363-3-L0).

The second variant is a robust convection/conduction cooling system tailored for Innovative X6 series modules which incorporates four high CFM air-flow fans solidly connected to a bold heat frame (80363-0-L0 and 80363-1-L0). This approach ensures sufficient cooling for high heat dissipating XMC modules.

The third variant is very similar to the second, but instead of X6 series it is custom tailored for Innovative XU series XMC modules (80363-4-L0 and 80363-5-L0).

All cooling options attach solidly to the Adapter carrier card and make direct use of the carrier's internal thermal plane.

This Adapter's cooling system is very effective because the dissipating heat is spread from the XMC module directly to the Adapter.

All cooling options conform to the VITA20 specification for PMC/XMC module cooling.

Innovative offers variety of customized heatsink options for different XMC modules. This information is accessible on the Innovative web site on the part ordering page. Please contact Innovative sales if assistance is needed to make a proper selection.

NOTE: It is always a good idea to monitor XMC module device temperatures and maintain it within the rated thermal limits.

Module Mounting Hardware

Mounting the XMC module to the adapter is very simple. Interconnect Systems International, LLC provides M2.5 screws with the Adapter to firmly attach the module to the heat frame after connector engagement.

NOTE: The use of a thermal gap pad, shims, or other thermally conductive materials is suggested for good contact between the XMC module and the heat frame. Variations in FPGA and other heat dissipating component heights need to be filled by thermally conductive material to obtain best heat transfer to the heat frame.

PCIe-XMC x8 Adapter

IMPORTANT NOTICES

Interconnect Systems International, LLC reserves the right to make corrections, modifications, enhancements, improvements, and other changes to its products and services at any time and to discontinue any product or service without notice. Customers should obtain the latest relevant information before placing orders and should verify that such information is current and complete. All products are sold subject to Interconnect Systems International, LLC 's terms and conditions of sale supplied at the time of order acknowledgment.

Interconnect Systems International, LLC warrants performance of its hardware products to the specifications applicable at the time of sale in accordance with Interconnect Systems International, LLC 's standard warranty. Testing and other quality control techniques are used to the extent Interconnect Systems International, LLC deems necessary to support this warranty. Except where mandated by government requirements, testing of all parameters of each product is not necessarily performed.

Interconnect Systems International, LLC assumes no liability for applications assistance or customer product design. Customers are responsible for their products and applications using Interconnect Systems International, LLC products. To minimize the risks associated with customer products and applications, customers should provide adequate design and operating safeguards.

Interconnect Systems International, LLC does not warrant or represent that any license, either express or implied, is granted under any Interconnect Systems International, LLC patent right, copyright, mask work right, or other Interconnect Systems International, LLC intellectual property right relating to any combination, machine, or process in which Interconnect Systems International, LLC products or services are used. Information published by Interconnect Systems International, LLC regarding third-party products or services does not constitute a license from Interconnect Systems International, LLC to use such products or services or a warranty or endorsement thereof. Use of such information may require a license from a third party under the patents or other intellectual property of the third party, or a license from Interconnect Systems International, LLC under the patents or other intellectual property of Interconnect Systems International, LLC .

Reproduction of information in Interconnect Systems International, LLC data sheets is permissible only if reproduction is without alteration and is accompanied by all associated warranties, conditions, limitations, and notices. Reproduction of this information with alteration is an unfair and deceptive business practice.

Interconnect Systems International, LLC is not responsible or liable for such altered documentation. Resale of Interconnect Systems International, LLC products or services with statements different from or beyond the parameters stated by Interconnect Systems International, LLC for that product or service voids all express and any implied warranties for the associated Interconnect Systems International, LLC product or service and is an unfair and deceptive business practice. Interconnect Systems International, LLC is not responsible or liable for any such statements.

For further information on Interconnect Systems International, LLC products and support see our web site:

www.isipkg.com

Mailing Address:

Interconnect Systems International, LLC, Inc.

741 Flynn Road, Camarillo, CA 93012